



MERCURY DISPLACEMENT INDUSTRIES, INC.

Post Office Box 710 - U.S. 12 East - Edwardsburg, Michigan 49112-0710

Phone (269) 663-8574 - Fax (269) 663-2924

(800) 634-4077

CONTROL PANEL

“50A754-C6-E7011” Model Duplex 230V 1 PH Grinder

Features & Benefits

- Circuit Breakers for Pump Circuits
- IEC Motor Contactor
- Easy to Access Terminal Block
- Alarm Silence & On-Off-Test Switches
- Externally Mounted Audible Alarm
- Pump Hand-Off-Auto Switches
- Pump Running Lights
- Alternating Relay for Reversible Pump
- Large External Alarm Light
- Fuse Protected Control & Alarm Circuits
- Ground Lugs
- Color Coded Internal Wiring
- Rugged Weather Resistant Hinged Enclosure w/Sst Latches
- Built and Labeled to UL 508A Standard w/Nema 4x Rating
- Provided with Wiring Schematic and Detailed Connection Diagram for Installer
- Seal Leak Indicator Light

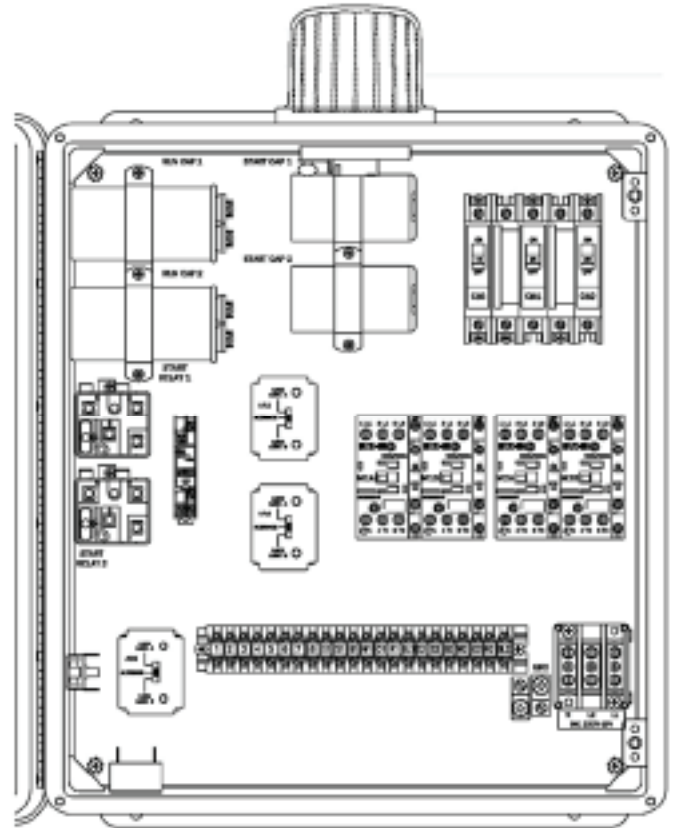

(Standard 50A754-C6-E7011 Model Shown)



*Note: Consult the factory for other available options. Also, some options may require an increase in the enclosure size. On single phase units, the pump model, cord configuration, and the start kit information are required

Contactors - Relays - Switches

<http://www.mdious.com>



MERCURY DISPLACEMENT INDUSTRIES, INC.

Post Office Box 710 - U.S. 12 East - Edwardsburg, Michigan 49112-0710

Phone (269) 663-8574 - Fax (269) 663-2924

(800) 634-4077

“50A754-C6-E7011” Model Duplex 230V 1 PH Grinder

Panel Dimensions

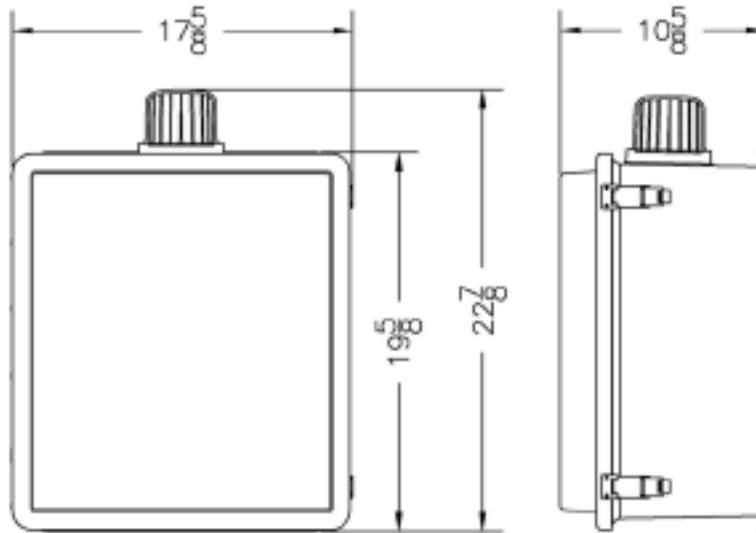

Panel Schematic

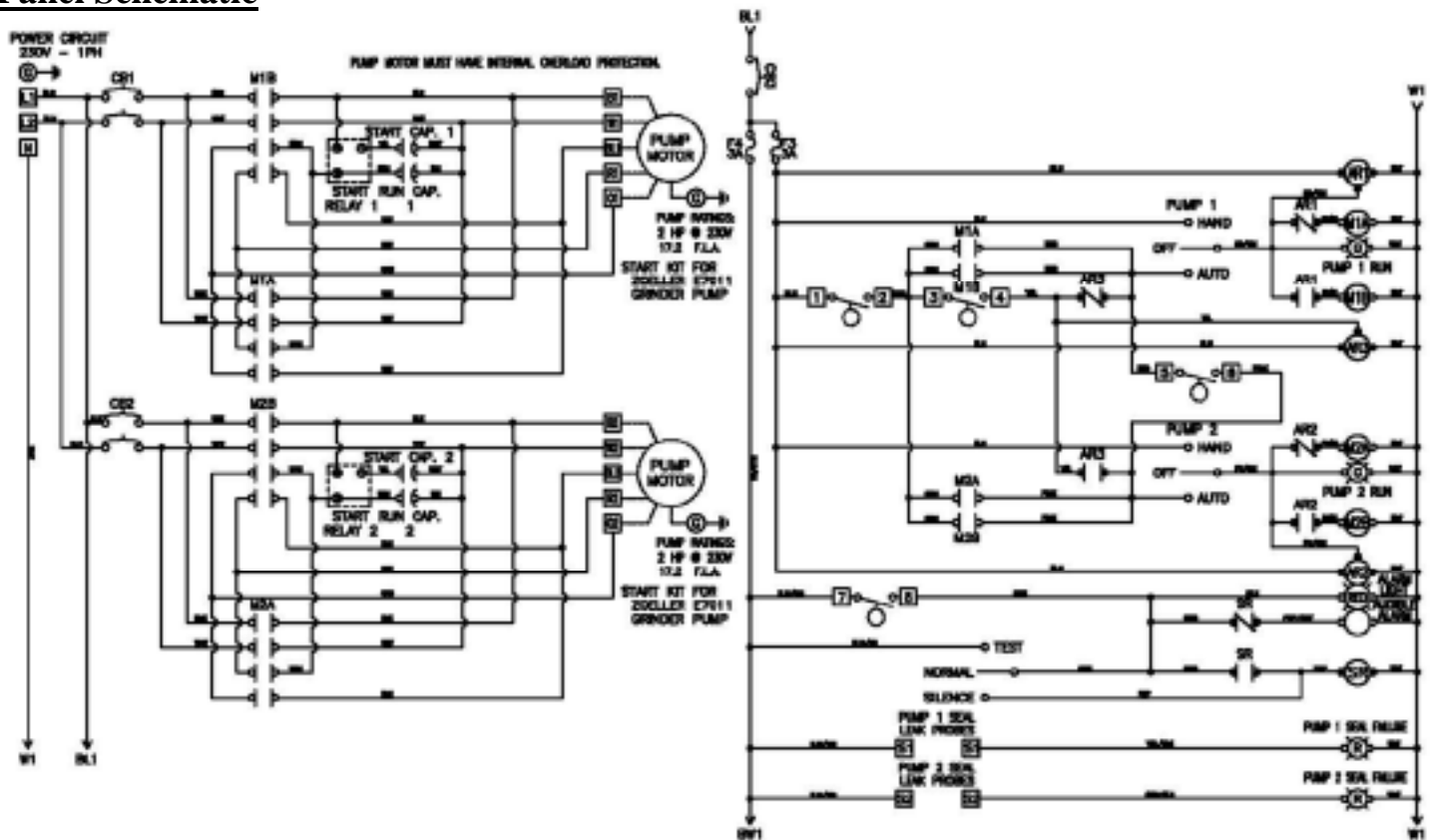

Contactors - Relays - Switches

<http://www.mdious.com>