



MERCURY DISPLACEMENT INDUSTRIES, INC.

Post Office Box 710 - U.S. 12 East - Edwardsburg, Michigan 49112-0710

Phone (269) 663-8574 - Fax (269) 663-2924

(800) 634-4077

# PANEL#: 50A750-C6

## CONNECTION DIAGRAM

### FLOAT & PUMP CONNECTIONS

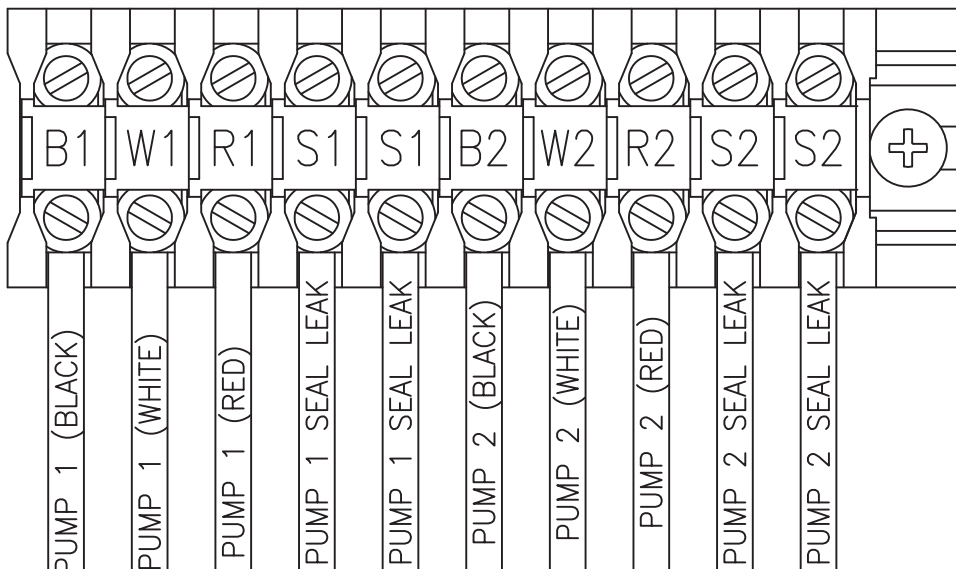
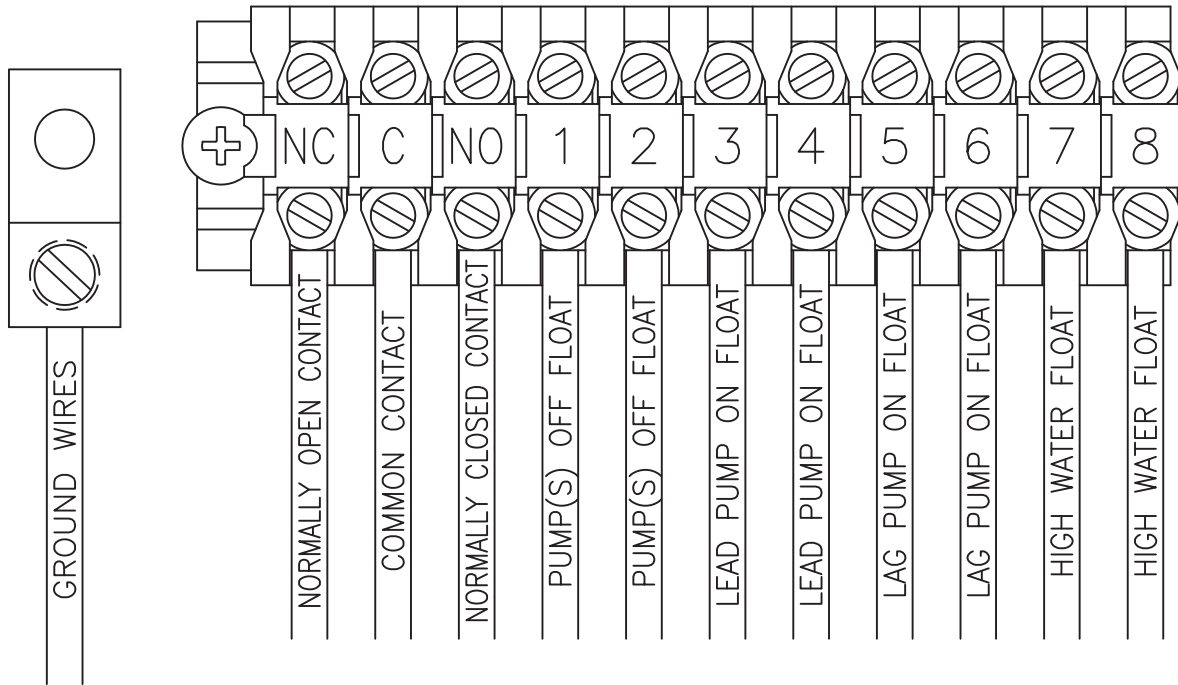

CONNECTION  
 DIAGRAM  
 230V-1 PH  
 DUPLEX  
 CONTROL PANEL

Contactors - Relays - Switches

<http://www.mdious.com>

POWER CIRCUIT  
115/230V - 1PH

PUMP MOTORS MUST HAVE INTERNAL OVERLOAD PROTECTION.

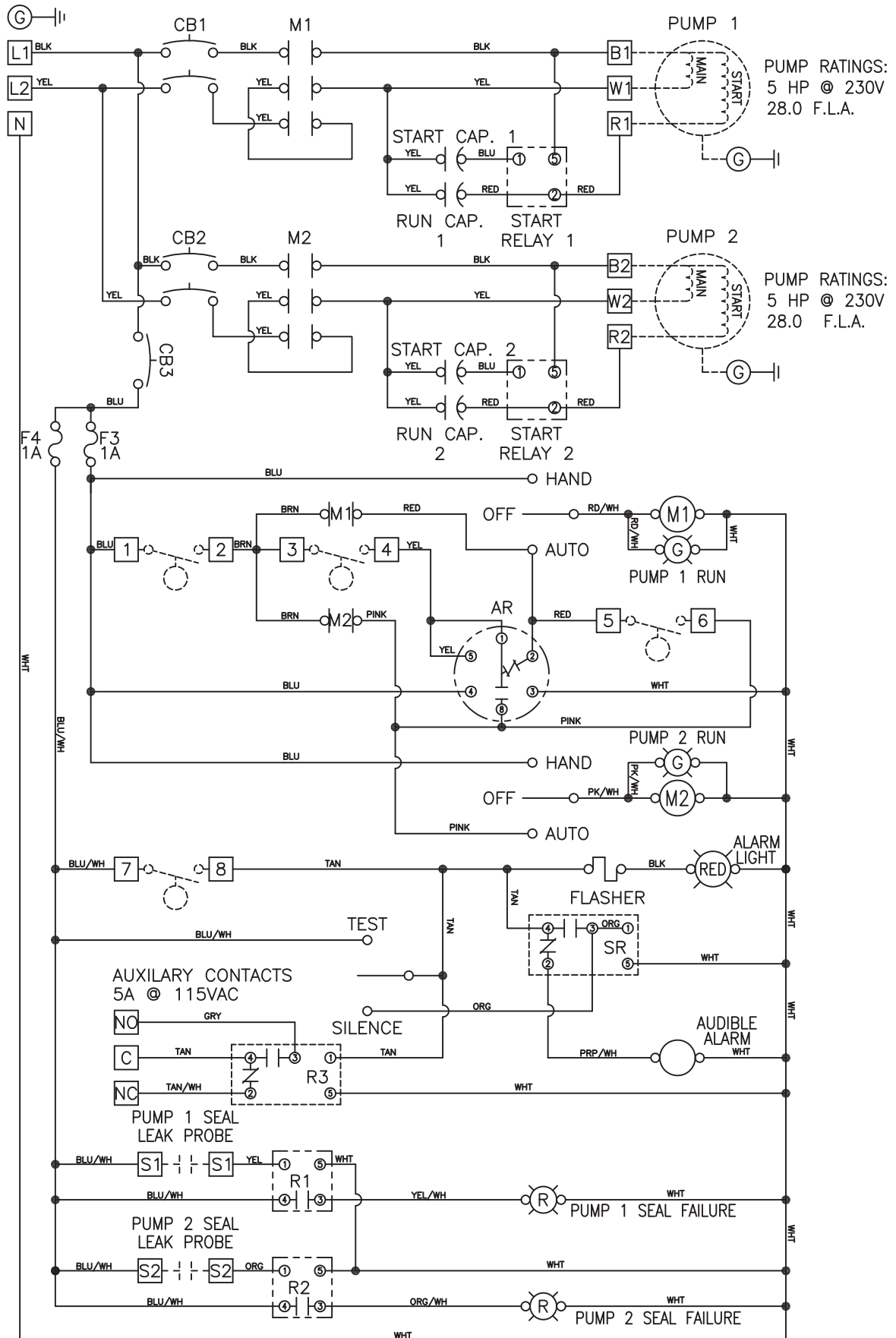

NOTES: FLOAT SWITCH TO BE RATED 2 AMPS @ 120V MINIMUM.  
MAIN PANEL DISCONNECT MUST BE PROVIDED BY INSTALLER.  
DASHED LINES INDICATE ITEM NOT CONTAINED IN THE PANEL.  
FIELD WIRING MUST BE A MINIMUM OF 60° COPPER WIRE.