



MERCURY DISPLACEMENT INDUSTRIES, INC.

Post Office Box 710 - U.S. 12 East - Edwardsburg, Michigan 49112-0710

Phone (269) 663-8574 - Fax (269) 663-2924

(800) 634-4077

CONTROL PANEL

“50A700” Simplex Grinder Pump Control Panel

Features & Benefits

- Circuit Breaker for Pump Circuit
- Definite Purpose Motor Contactor
- Easy to Access Terminal Block
- Single & Three Phase Available
- Start Component Included on Single Phase (Start & Run Capacitor, Start Relay)*
- Externally Mounted Test/Normal/Silence Switch w/UV Resistant Sealing Boot
- Externally Mounted Audible Alarm
- Pump Hand-Off-Auto Switch
- Pump Running Light
- Large External Alarm Light
- Control & Alarm Circuit Breaker
- Ground Lugs
- Color Coded Internal Wiring
- Rugged Weather Resistant Hinged Poly Enclosure w/Sst Latches
- Built and Labeled to UL 508A Standard w/Nema 4x Rating
- Provided with Wiring Schematic and Detailed Connection Diagram for Installer
- Mounting Feet for Enclosure

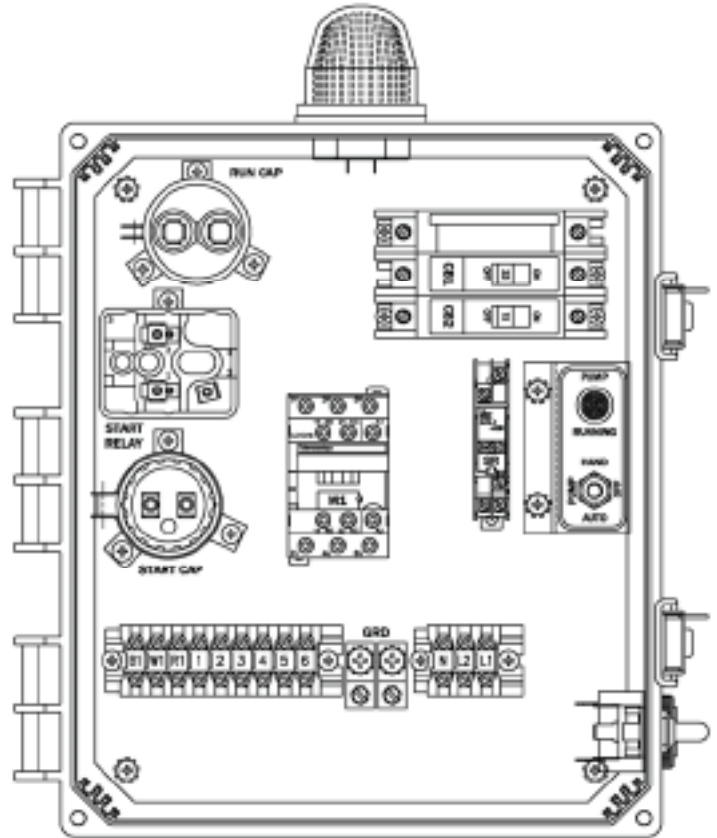

(Standard 50A700 Shown)

Available Options(*)

- Fiberglass Enclosure
- Seal Leak Detection Circuitry
- Heat Sensor Connections
- IEC Motor Contactor with Overload
- Flasher
- Dead Front Inner Door
- Auxiliary Alarm Contacts
- Elapsed Timer Meters or Cycle Counters
- Mercury or Mechanical Float Switches for the Pumps and High Water Alarm Circuits

*Note: Consult the factory for other available options. Also, some options may require an increase in the enclosure size. On single phase units, the pump model, cord configuration, and the start kit information are required



Contactors - Relays - Switches

<http://www.mdious.com>



MERCURY DISPLACEMENT INDUSTRIES, INC.

Post Office Box 710 - U.S. 12 East - Edwardsburg, Michigan 49112-0710

Phone (269) 663-8574 - Fax (269) 663-2924

(800) 634-4077

“50A700” Simplex Grinder Pump Control Panel

Panel Dimensions

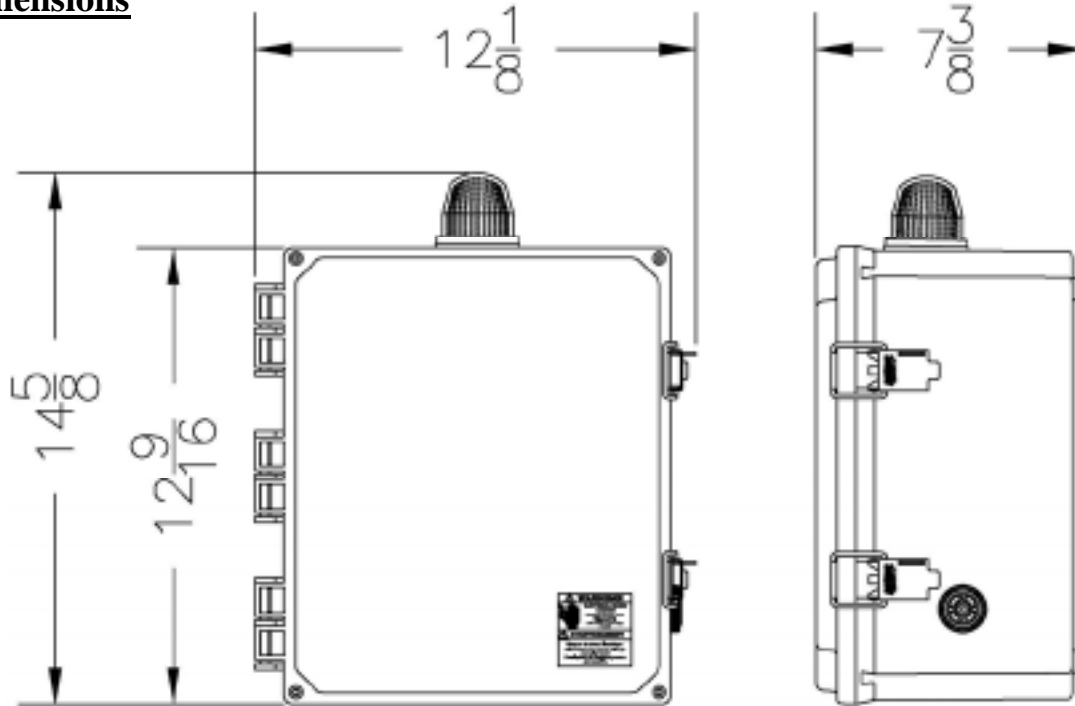

Panel Schematic

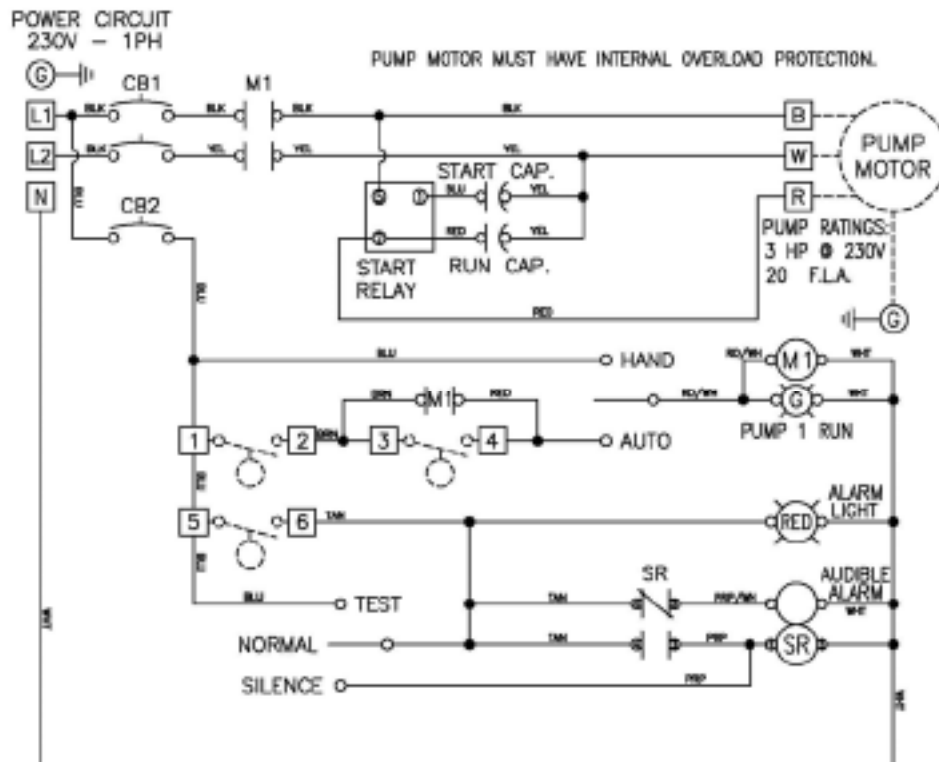

Contactors - Relays - Switches

<http://www.mdious.com>