



MERCURY DISPLACEMENT INDUSTRIES, INC.

Post Office Box 710 - U.S. 12 East - Edwardsburg, Michigan 49112-0710

Phone (269) 663-8574 - Fax (269) 663-2924

(800) 634-4077

PANEL#: 50A700

CONNECTION DIAGRAM

REQUIRED TORQUE FOR TERMINAL BLOCK SCREWS IS 16 in-lbs.

INCOMING POWER CONNECTION

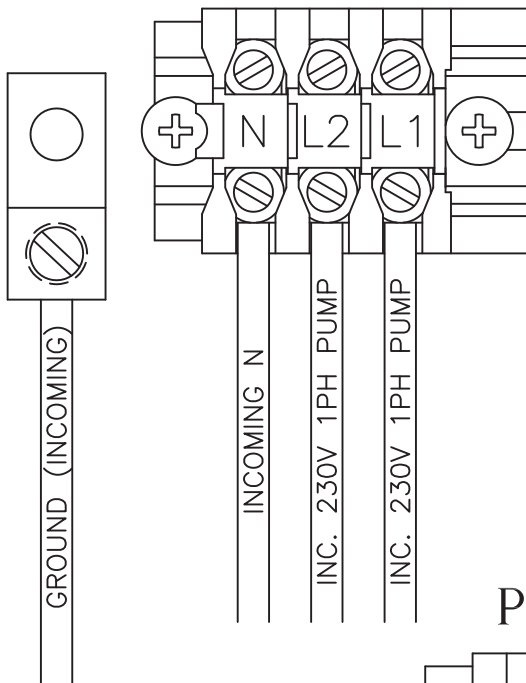

PUMP & FLOAT CONNECTIONS

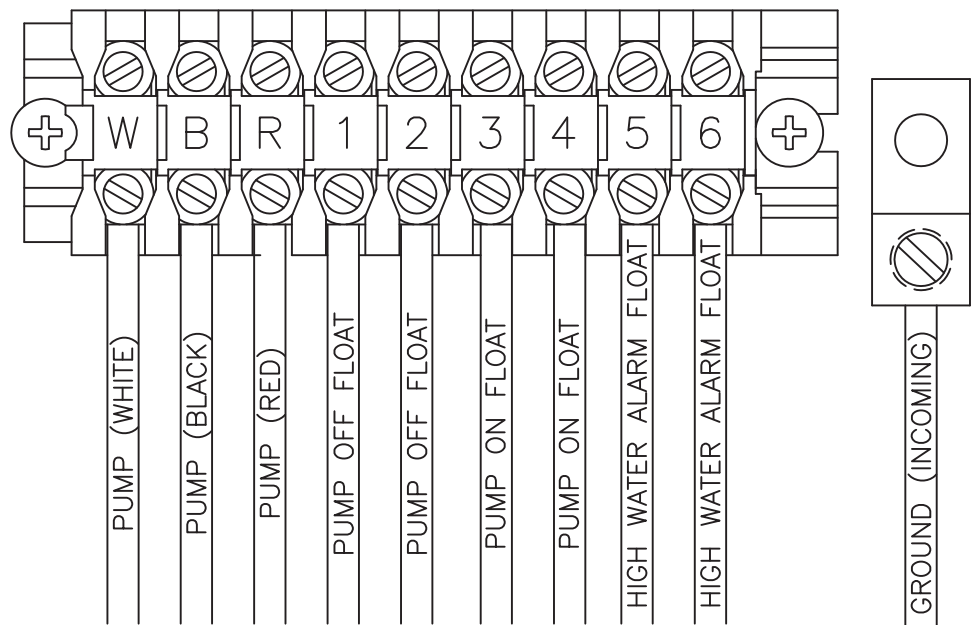

Contactors - Relays - Switches

<http://www.mdious.com>



MERCURY DISPLACEMENT INDUSTRIES, INC.

Post Office Box 710 - U.S. 12 East - Edwardsburg, Michigan 49112-0710

Phone (269) 663-8574 - Fax (269) 663-2924

(800) 634-4077

POWER CIRCUIT
230V - 1PH

PUMP MOTOR MUST HAVE INTERNAL OVERLOAD PROTECTION.

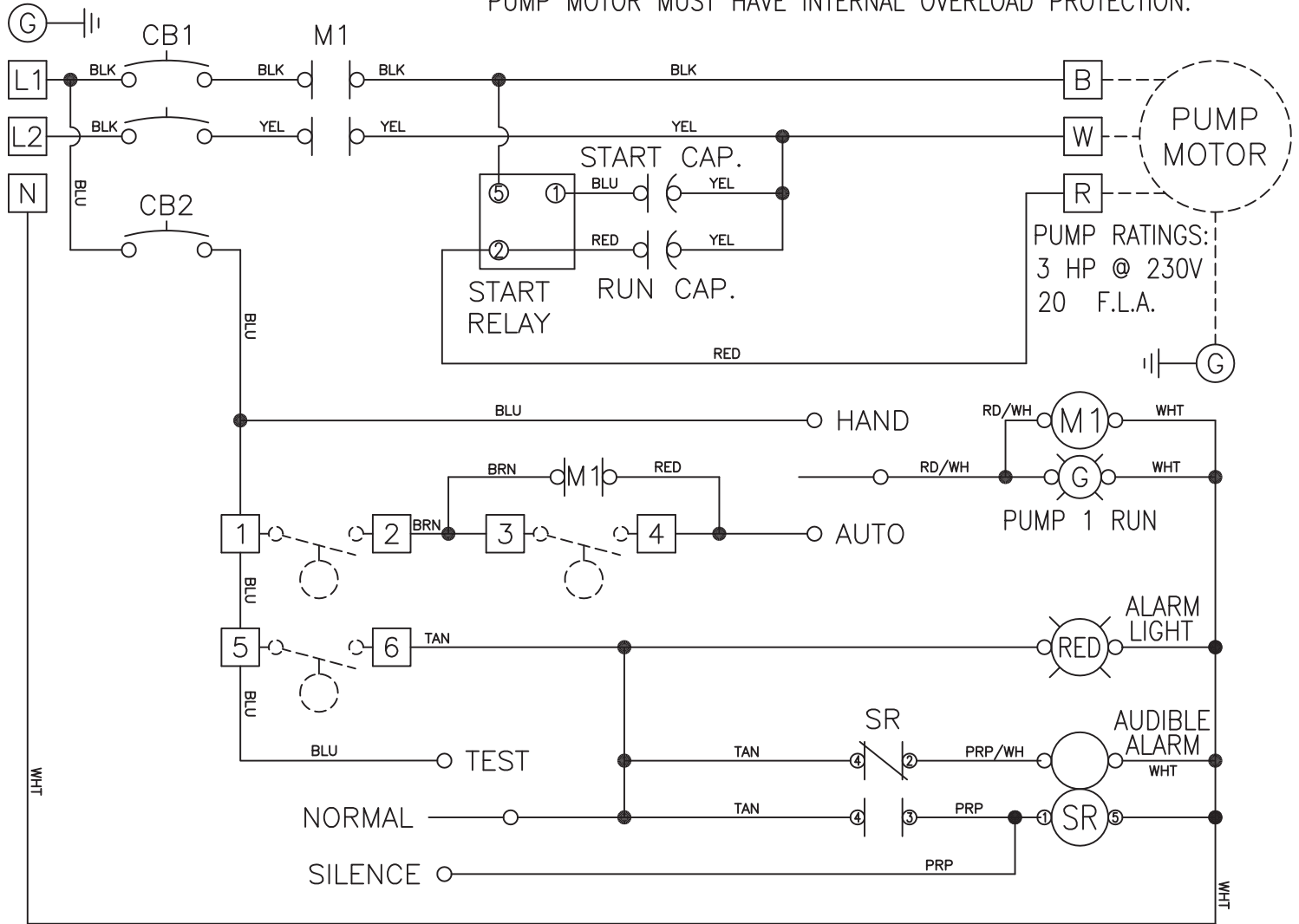

NOTES: FLOAT SWITCH TO BE RATED 2 AMP AT 120V MINIMUM.
 MAIN PANEL DISCONNECT MUST BE PROVIDED BY INSTALLER.
 DASHED LINES INDICATE ITEMS NOT CONTAINED IN THE PANEL.
 FIELD WIRING MUST BE A MINIMUM OF 60°C COPPER WIRE.