



MERCURY DISPLACEMENT INDUSTRIES, INC.

Post Office Box 710 - U.S. 12 East - Edwardsburg, Michigan 49112-0710

Phone (269) 663-8574 - Fax (269) 663-2924

(800) 634-4077

PANEL #: 50A502

CONNECTION DIAGRAM

REQUIRED TORQUE FOR TERMINAL BLOCK SCREWS IS 16 in.-lbs.

(4 FLOAT SYSTEM)

INCOMING POWER CONNECTIONS

PUMP & FLOAT CONNECTIONS

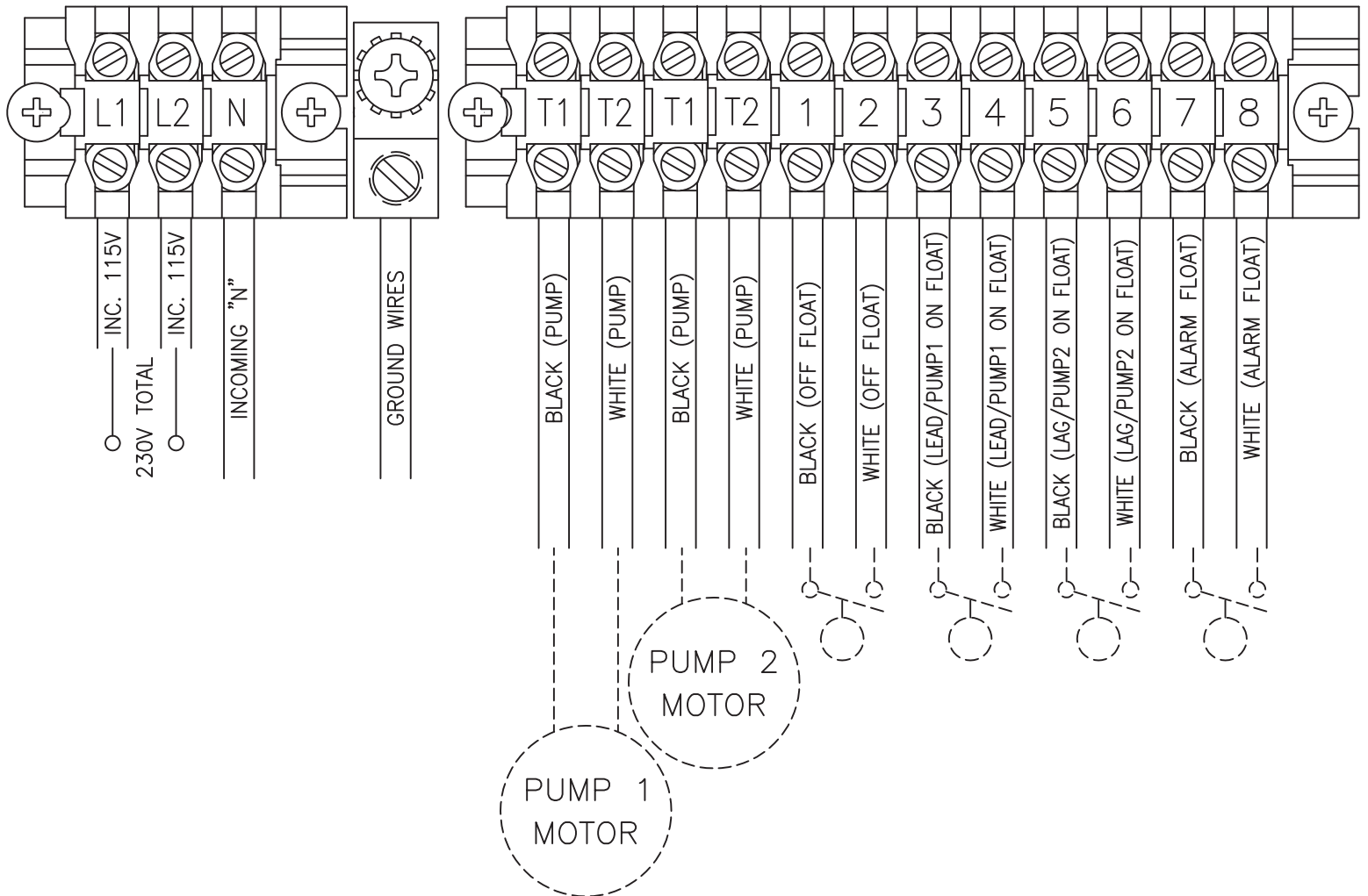

Contactors - Relays - Switches

<http://www.mdius.com>

TIGHTENING TORQUE FOR TERMINAL BLOCK IS 16 in-lbs.

CONNECTION DIAGRAM (3 FLOAT SYSTEM)

INCOMING POWER CONNECTIONS

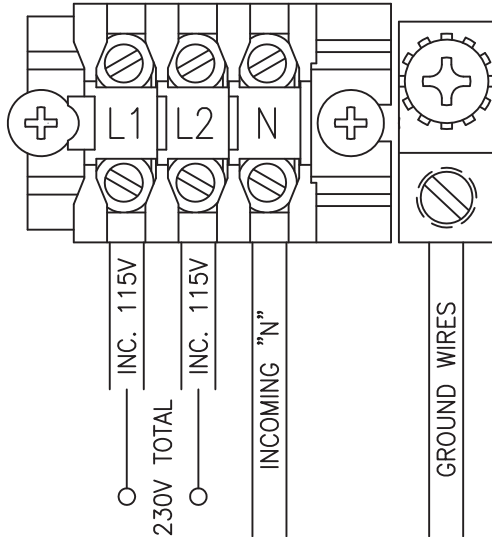

PUMP & FLOAT CONNECTIONS

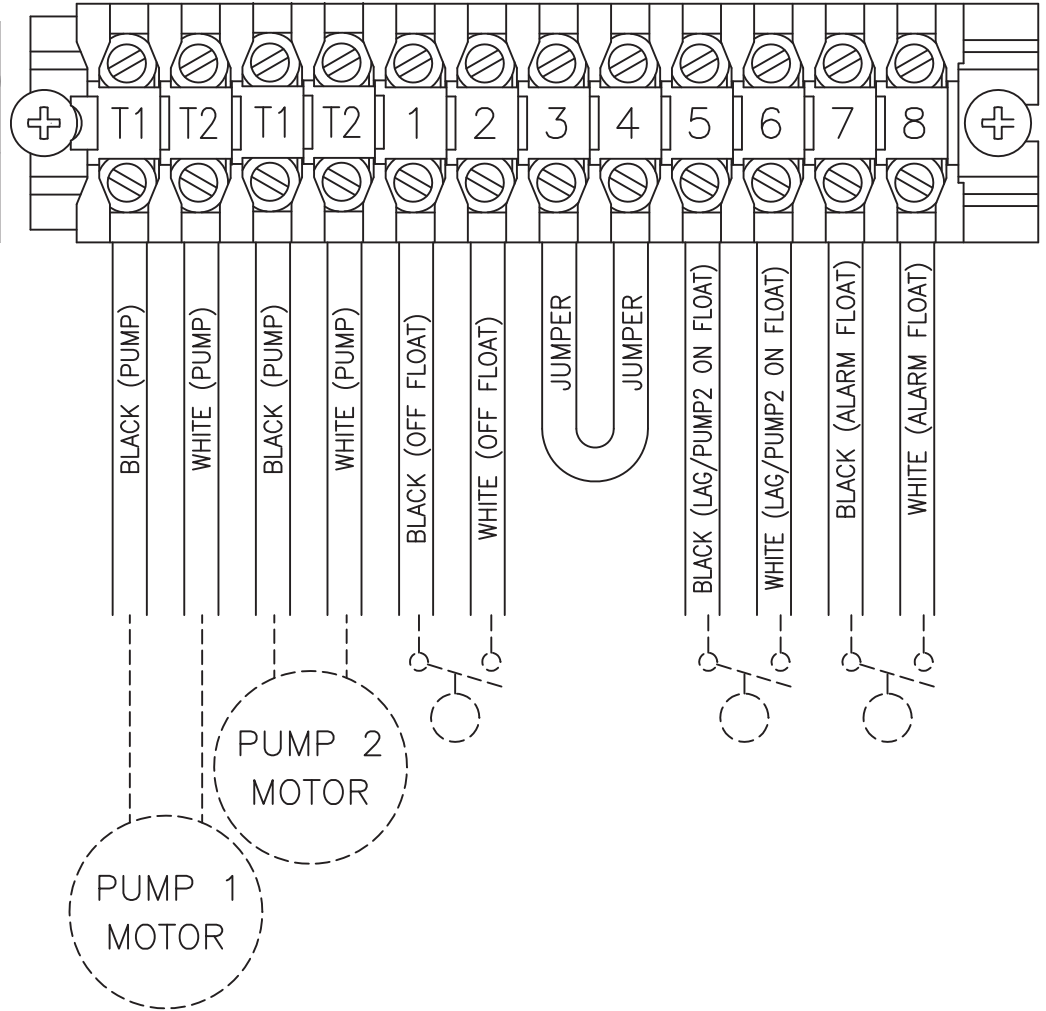



MERCURY DISPLACEMENT INDUSTRIES, INC.

Post Office Box 710 - U.S. 12 East - Edwardsburg, Michigan 49112-0710

Phone (269) 663-8574 - Fax (269) 663-2924

(800) 634-4077

POWER CIRCUIT
230V - 1PH

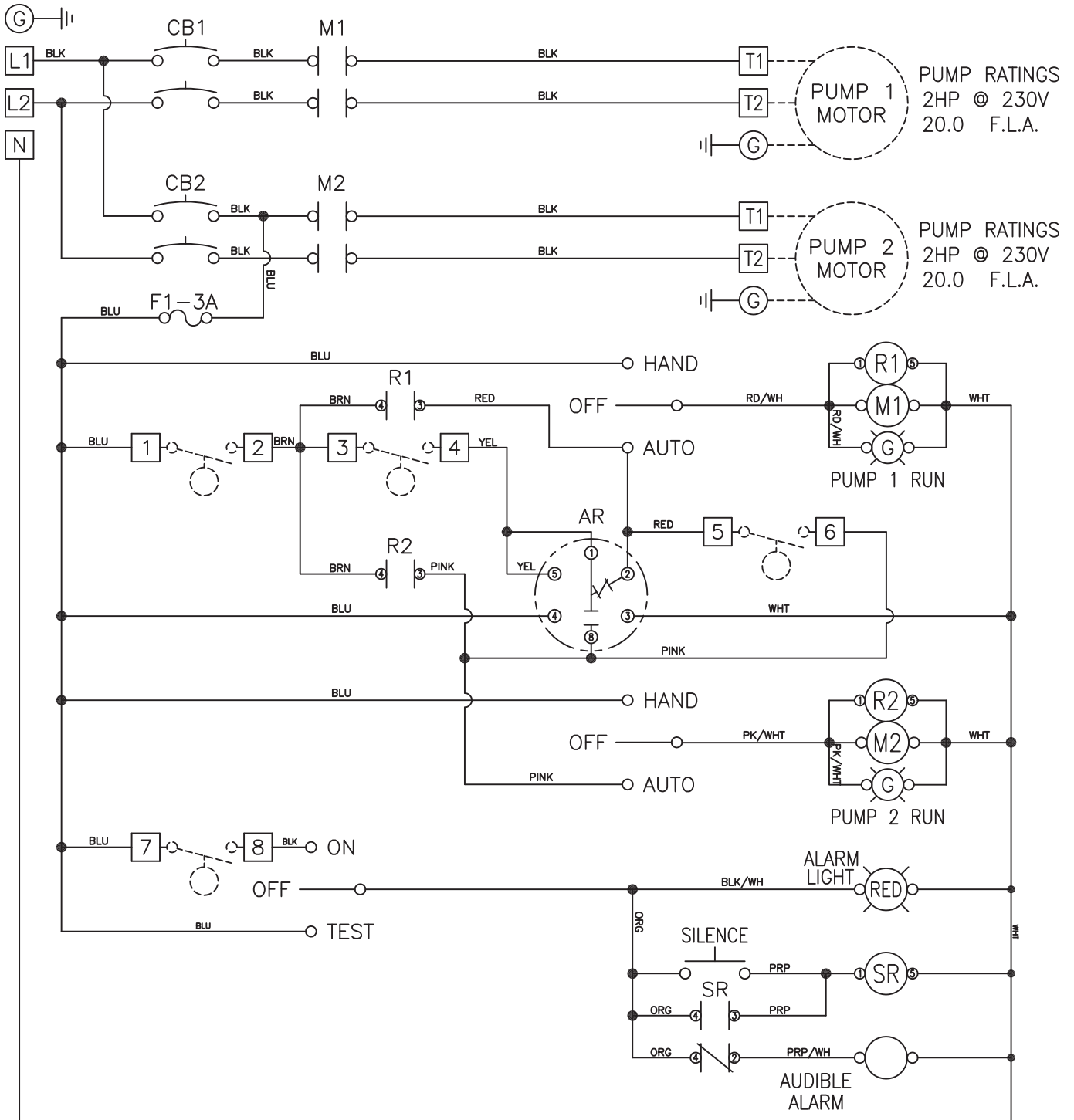

NOTES: FLOAT SWITCH TO BE RATED 2 AMP AT 120V MINIMUM.
 MAIN PANEL DISCONNECT MUST BE PROVIDED BY INSTALLER.
 DASHED LINES INDICATE ITEMS NOT CONTAIN IN THE PANEL.
 FIELD WIRING MUST BE A MINIMUM OF 60°C COPPER WIRE.

Contactors - Relays - Switches

<http://www.mdious.com>