



MERCURY DISPLACEMENT INDUSTRIES, INC.

Post Office Box 710 - U.S. 12 East - Edwardsburg, Michigan 49112-0710

Phone (269) 663-8574 - Fax (269) 663-2924

(800) 634-4077

“50A008” Model Simplex 3 Phase Control Panel

Features & Benefits

- Circuit Breakers for Pump Circuit
- Circuit Breaker for Controls & Alarm
- IEC Motor Contactor & Overload
- Easy to Access Terminal Block
- Usable with 460 VAC
- Externally Mounted Test/Normal/Silence Switch w/UV resistant sealing boot
- Externally Mounted Audible Alarm
- Pump Hand-Off-Auto Switch
- Pump Running Light
- Transformer w/Primary & Secondary Fuse Protection
- Large External Alarm Light
- Separate Control & Alarm Fuses
- Ground Lugs
- Color Coded Internal Wiring
- Rugged Weather Resistant Hinged Poly Enclosure w/Sst Latches
- Built and Labeled to UL 508A Standard w/Nema 4x Rating
- Provided with Wiring Schematic and Detailed Connection Diagram for Installer
- Mounting Feet for Enclosure

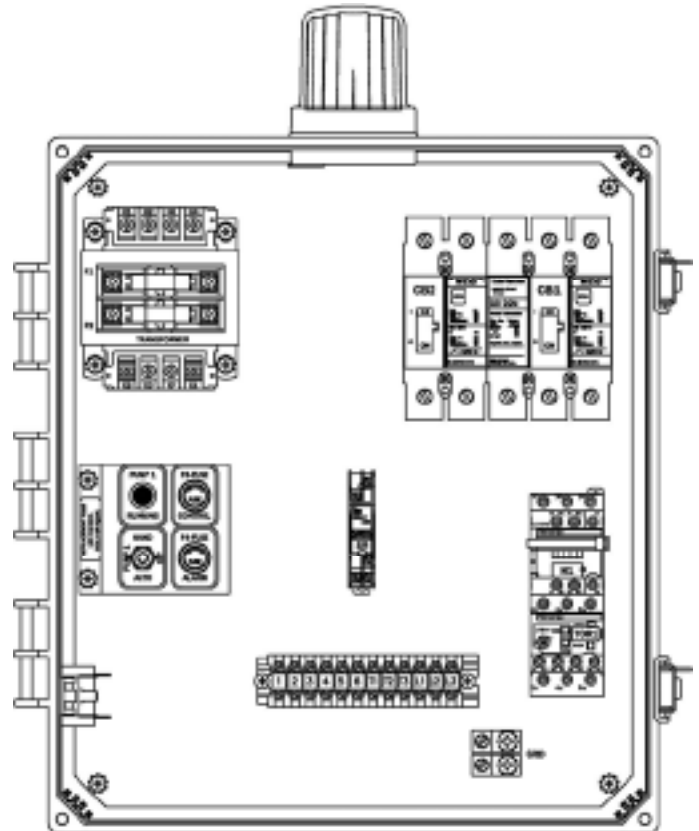

(Standard 50A008 Shown)



Available Options(*)

- Fiberglass Enclosure
- Flasher
- Dead Front Inner Door
- Auxiliary Alarm Contacts
- Mercury or Mechanical Float Switches for the Pumps and High Water Alarm Circuits

*Note: Consult the factory for other available options. Also, some options may require an increase in the enclosure size.

Contactors - Relays - Switches

<http://www.mdius.com>



MERCURY DISPLACEMENT INDUSTRIES, INC.

Post Office Box 710 - U.S. 12 East - Edwardsburg, Michigan 49112-0710

Phone (269) 663-8574 - Fax (269) 663-2924

(800) 634-4077

“50A008” Model Simplex 3 Phase Control Panel

Panel Dimensions

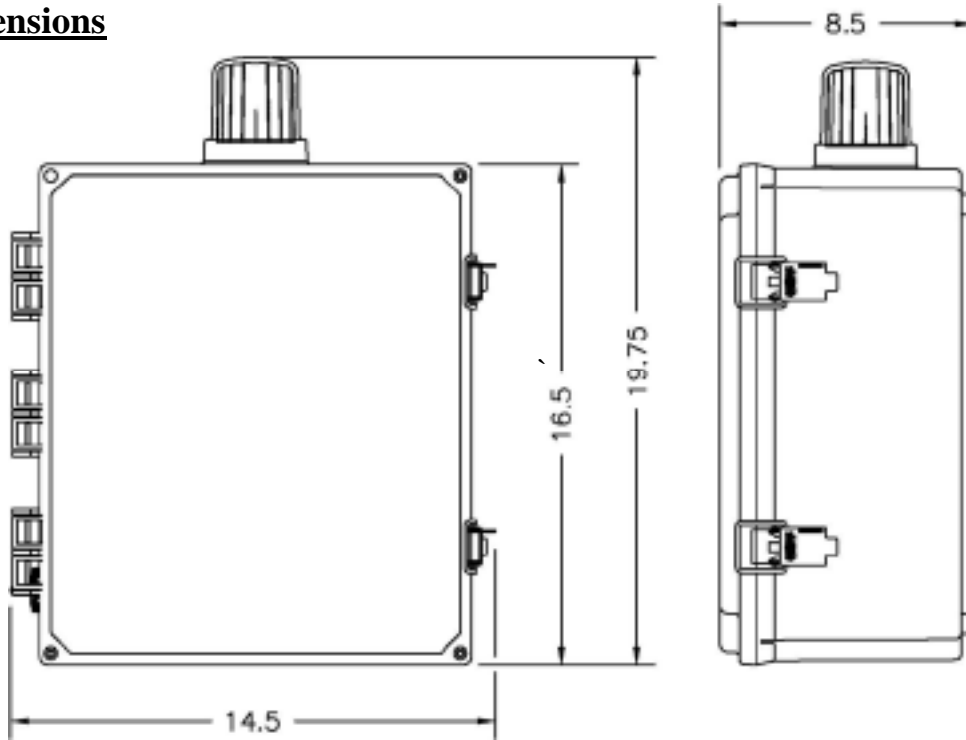

Panel Schematic

POWER CIRCUIT (3 WIRE SERVICE)
480V - 3PH - 60Hz

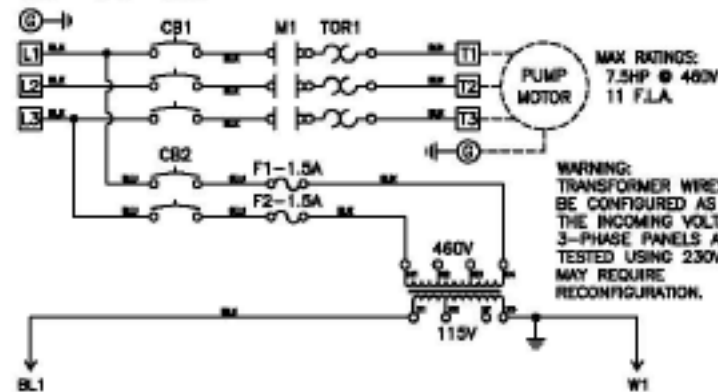

MAX RATINGS:
7.5HP @ 460V
11 F.L.A.

WARNING:
TRANSFORMER WIRES MUST
BE CONFIGURED AS PER
THE INCOMING VOLTAGE. ALL
3-PHASE PANELS ARE
TESTED USING 230V AND
MAY REQUIRE
RECONFIGURATION.

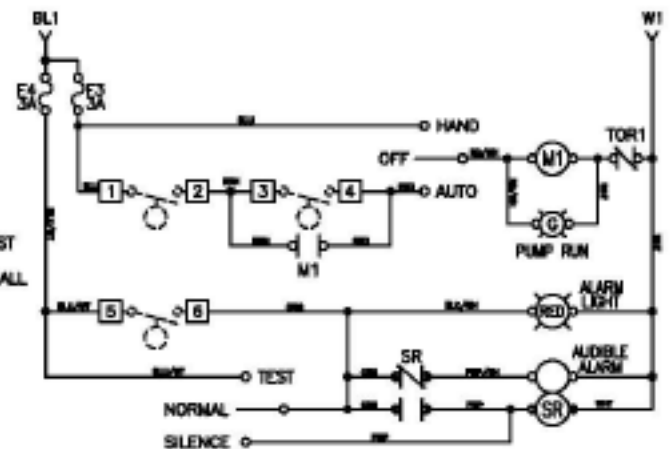

Contactors - Relays - Switches

<http://www.mdious.com>