



MERCURY DISPLACEMENT INDUSTRIES, INC.

Post Office Box 710 - U.S. 12 East - Edwardsburg, Michigan 49112-0710

Phone (269) 663-8574 - Fax (269) 663-2924

(800) 634-4077

PANEL #: 50A008

CONNECTION DIAGRAM

REQUIRED TORQUE FOR TERMINAL BLOCK SCREWS IS 16 in-lbs.

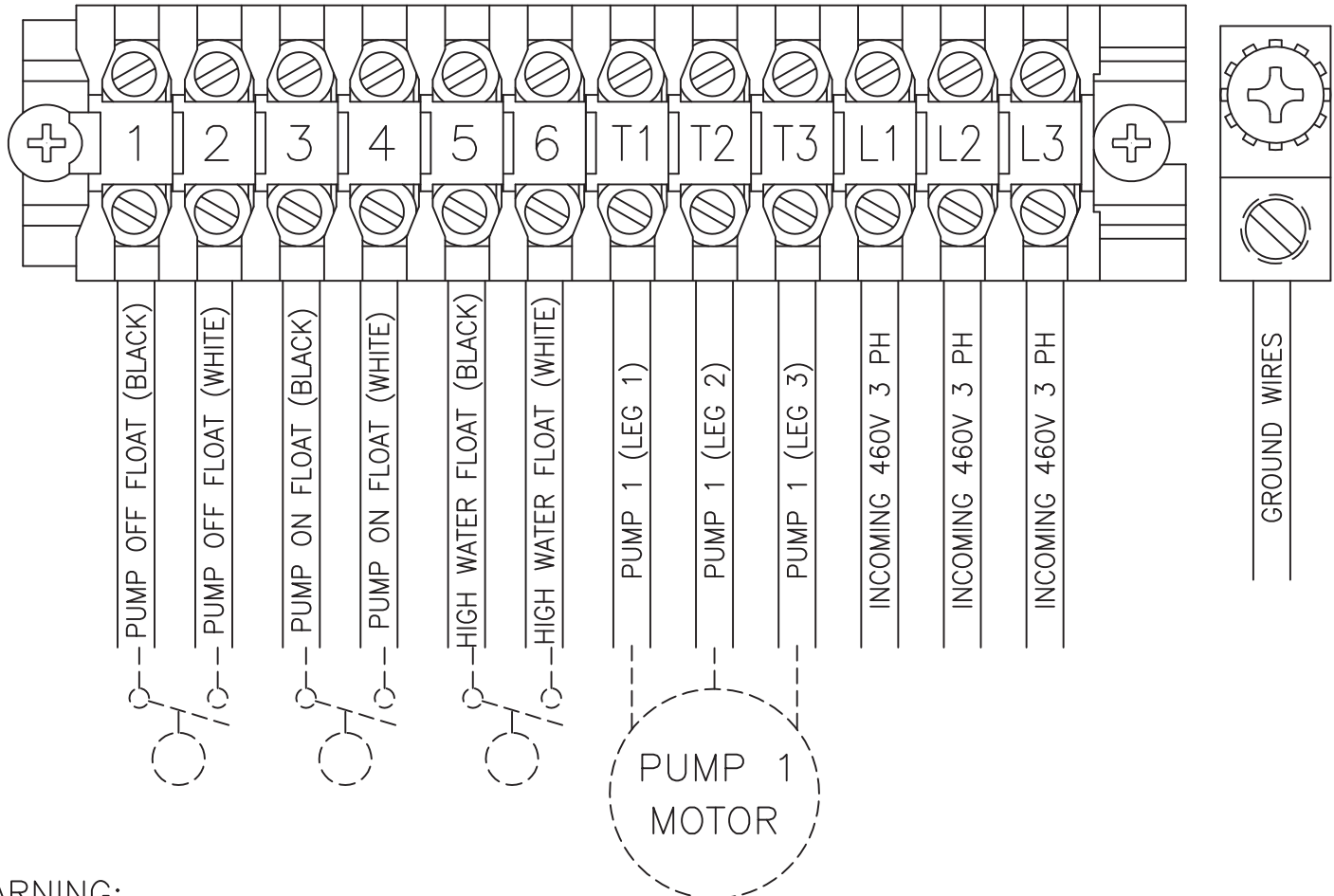

WARNING:

TRANSFORMER WIRES MUST BE CONFIGURED AS PER THE INCOMING VOLTAGE. ALL 3-PHASE PANELS ARE TESTED USING 230V AND MAY REQUIRE RECONFIGURATION.

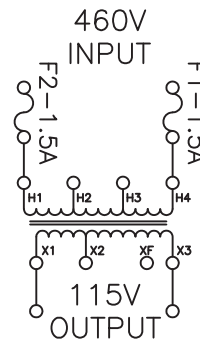
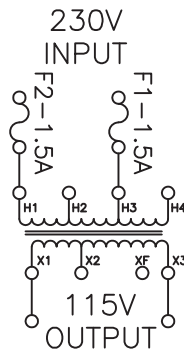
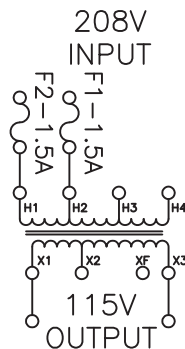

Contactors - Relays - Switches

<http://www.mdious.com>

POWER CIRCUIT (3 WIRE SERVICE)
460V - 3PH - 60Hz

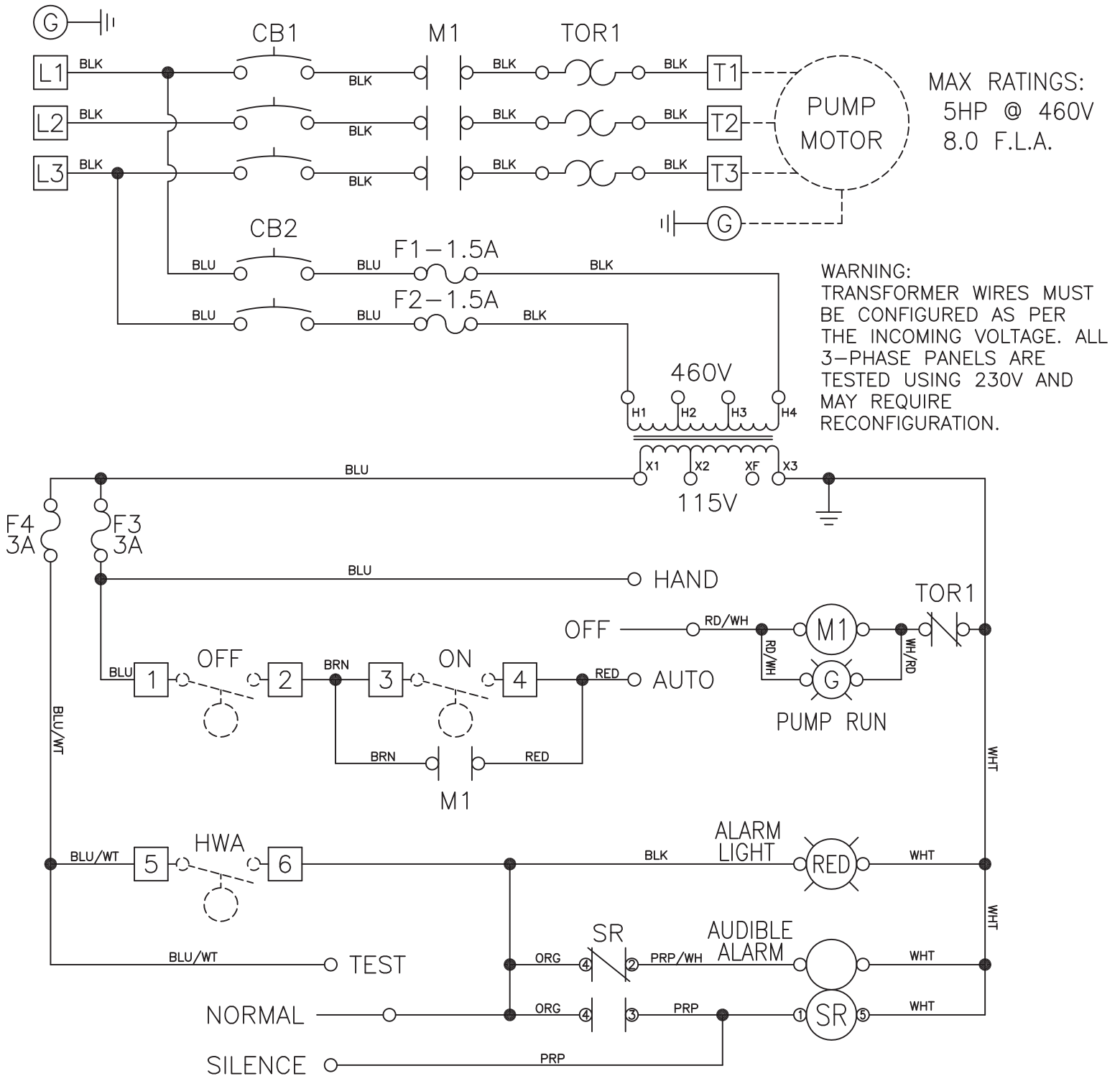

NOTES: FLOAT SWITCH TO BE RATED 2 AMP AT 120V MINIMUM.
MAIN PANEL DISCONNECT MUST BE PROVIDED BY INSTALLER.
DASHED LINES INDICATE ITEMS NOT CONTAIN IN THE PANEL.
REQUIRED TORQUE FOR TERMINAL BLOCK SCREWS IS 16 in-lbs.
FIELD WIRING MUST BE A MINIMUM OF 60°C COPPER WIRE.