



# MERCURY DISPLACEMENT INDUSTRIES, INC.

Post Office Box 710 - U.S. 12 East - Edwardsburg, Michigan 49112-0710

Phone (269) 663-8574 - Fax (269) 663-2924

(800) 634-4077

## 50A006-CBXST Model Simplex 115/208/230V 1 Phase Control Panel

### Features & Benefits

- Circuit Breakers for Pump Circuit
- Definite Purpose Contactor
- Easy to Access Terminal Block
- Usable with 115, 208 or 230 VAC
- Alarm Silence & On-Off-Test Switches
- Externally Mounted Audible Alarm
- Pump Hand-Off-Auto Switch
- Pump Running Light
- External Alarm Light
- Ground Lugs
- Color Coded Internal Wiring
- Rugged Weather Resistant Hinged Poly Enclosure w/Sst Latch
- Built and Labeled to UL 508A Standard w/Nema 4x Rating
- Provided with Wiring Schematic and Detailed Connection Diagram for Installer
- Mounting Feet for Enclosure
- External Test & Alarm Silence

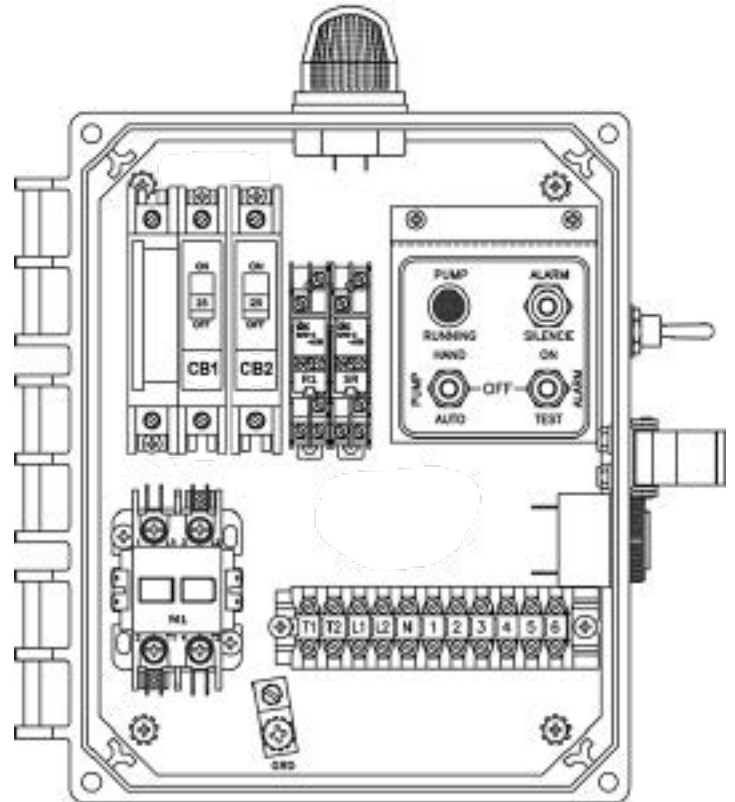

### Available Options (\*)

- Fiberglass Enclosure
- IEC Motor Contactor
- Flasher
- Dead Front Inner Door
- Auxiliary Alarm Contacts
- Elapsed Time Meter
- Event or Cycle Counter
- Mercury or Mechanical Float Switches for the Pumps and High Water Alarm Circuits



Contactors - Relays - Switches

<http://www.mdious.com>



# MERCURY DISPLACEMENT INDUSTRIES, INC.

Post Office Box 710 - U.S. 12 East - Edwardsburg, Michigan 49112-0710

Phone (269) 663-8574 - Fax (269) 663-2924

(800) 634-4077

## 50A006-CBXST Model Simplex 115/208/230V 1 Phase Control Panel

### Panel Dimensions

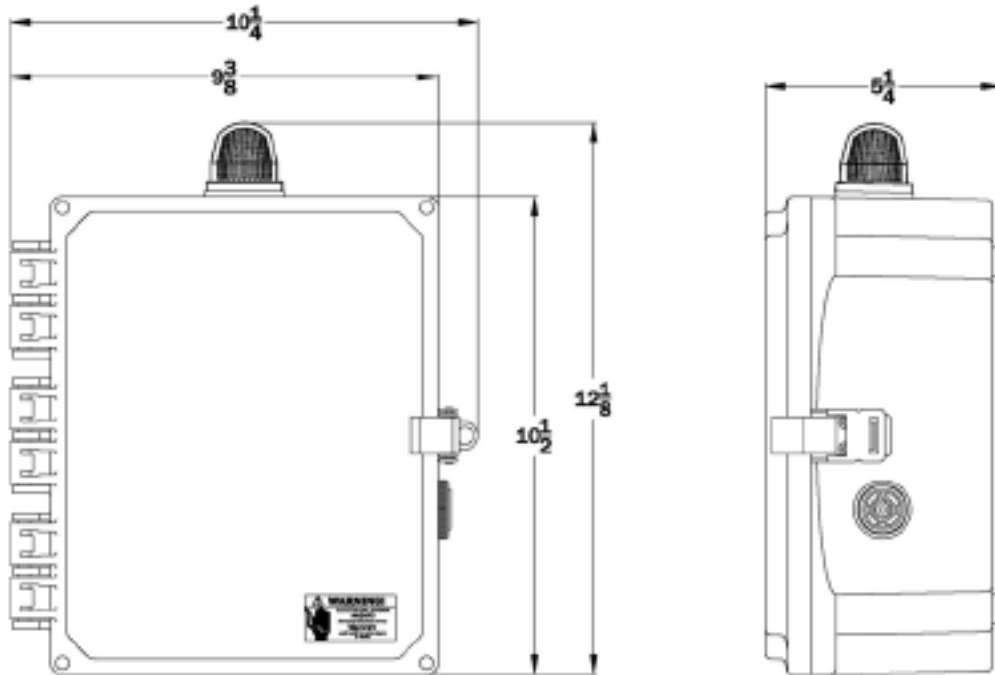

### Panel Schematic

POWER CIRCUIT  
115/230V - 1PH

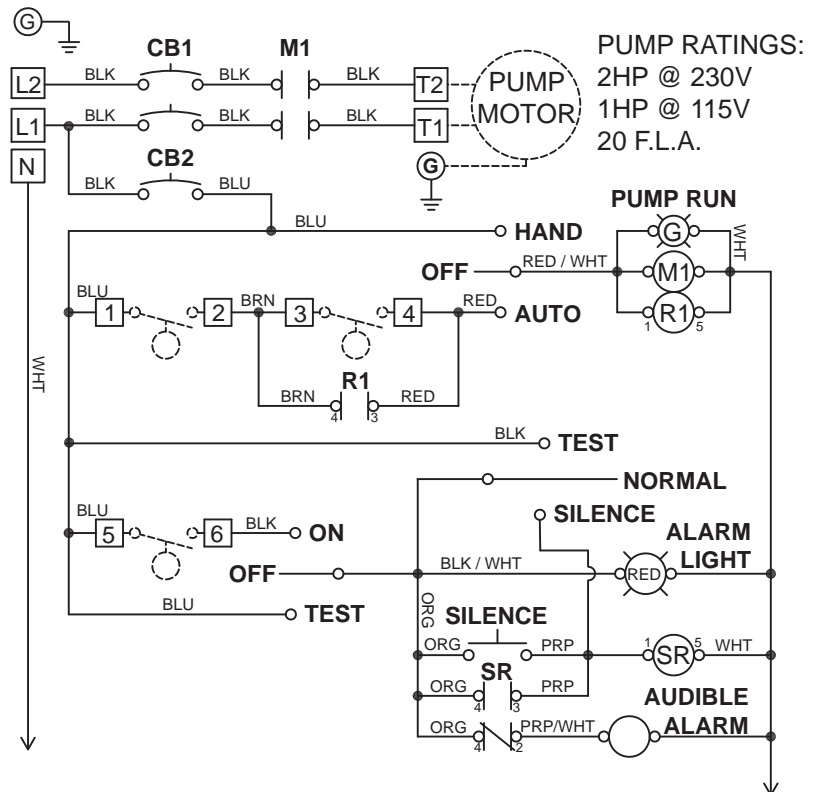

PUMP RATINGS:  
2HP @ 230V  
1HP @ 115V  
20 F.L.A.

NOTES:  
PUMP MOTOR MUST HAVE INTERNAL OVERLOAD PROTECTION  
FLOAT SWITCH TO BE RATED 2 AMP @ 120V MINIMUM.  
MAIN PANEL DISCONNECT MUST BE PROVIDED BY INSTALLER.  
DASHED LINES INDICATE ITEMS NOT CONTAIN IN THE PANEL.  
REQUIRED TORQUE FOR TERMINAL BLOCK SCREWS IS 8 IN-LBS.  
FIELD WIRING MUST BE A MINIMUM OF 60° COPPER WIRE.

Contactors - Relays - Switches

<http://www.mdious.com>