



MERCURY DISPLACEMENT INDUSTRIES, INC.

Post Office Box 710 - U.S. 12 East - Edwardsburg, Michigan 49112-0710

Phone (269) 663-8574 - Fax (269) 663-2924

(800) 634-4077

PANEL #: 50A001

CONNECTION DIAGRAM

REQUIRED TORQUE FOR TERMINAL BLOCK SCREWS IS 16 in-lbs.

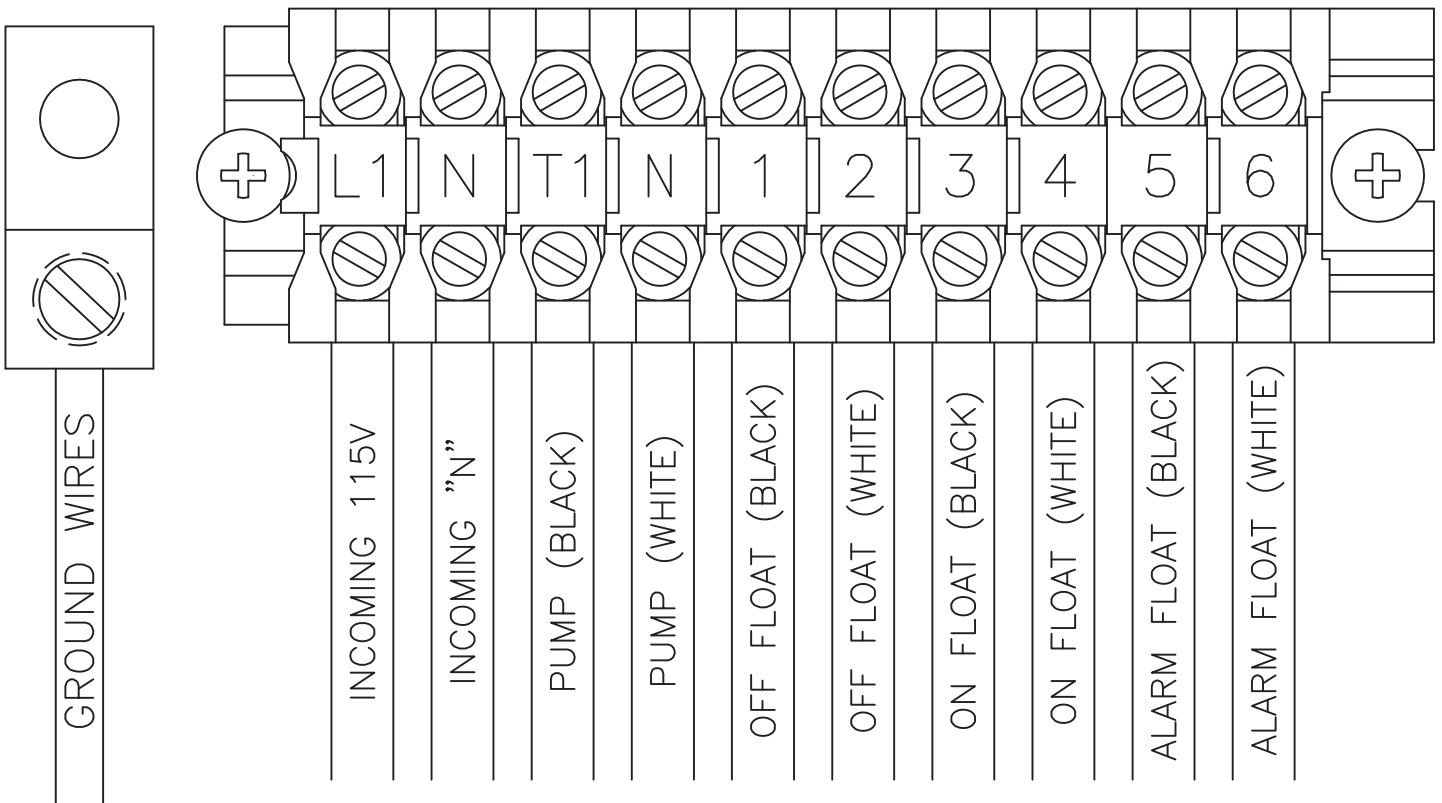

Contactors - Relays - Switches

<http://www.mdious.com>

**POWER CIRCUIT
115V - 1PH**

**NOTE: PUMP MOTOR MUST HAVE
INTERNAL OVERLOAD PROTECTION.**

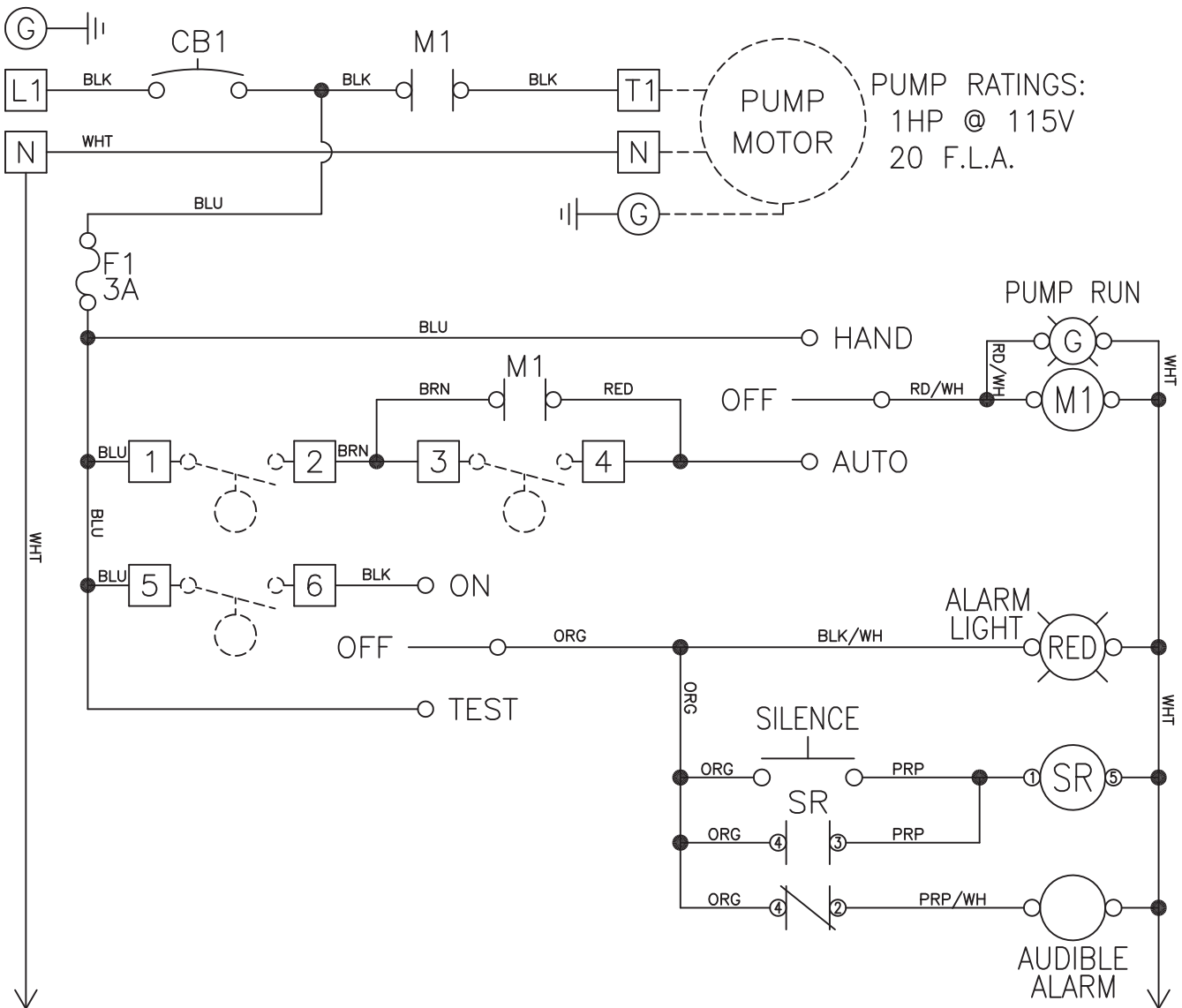

- NOTES:**
- FLOAT SWITCH TO BE RATED 2 AMP @ 120V MINIMUM.
 - MAIN PANEL DISCONNECT MUST BE PROVIDED BY INSTALLER.
 - DASHED LINES INDICATE ITEMS NOT CONTAIN IN THE PANEL.
 - REQUIRED TORQUE FOR TERMINAL BLOCK SCREWS IS 8 IN-LBS.
 - FIELD WIRING MUST BE A MINIMUM OF 60° COPPER WIRE.