

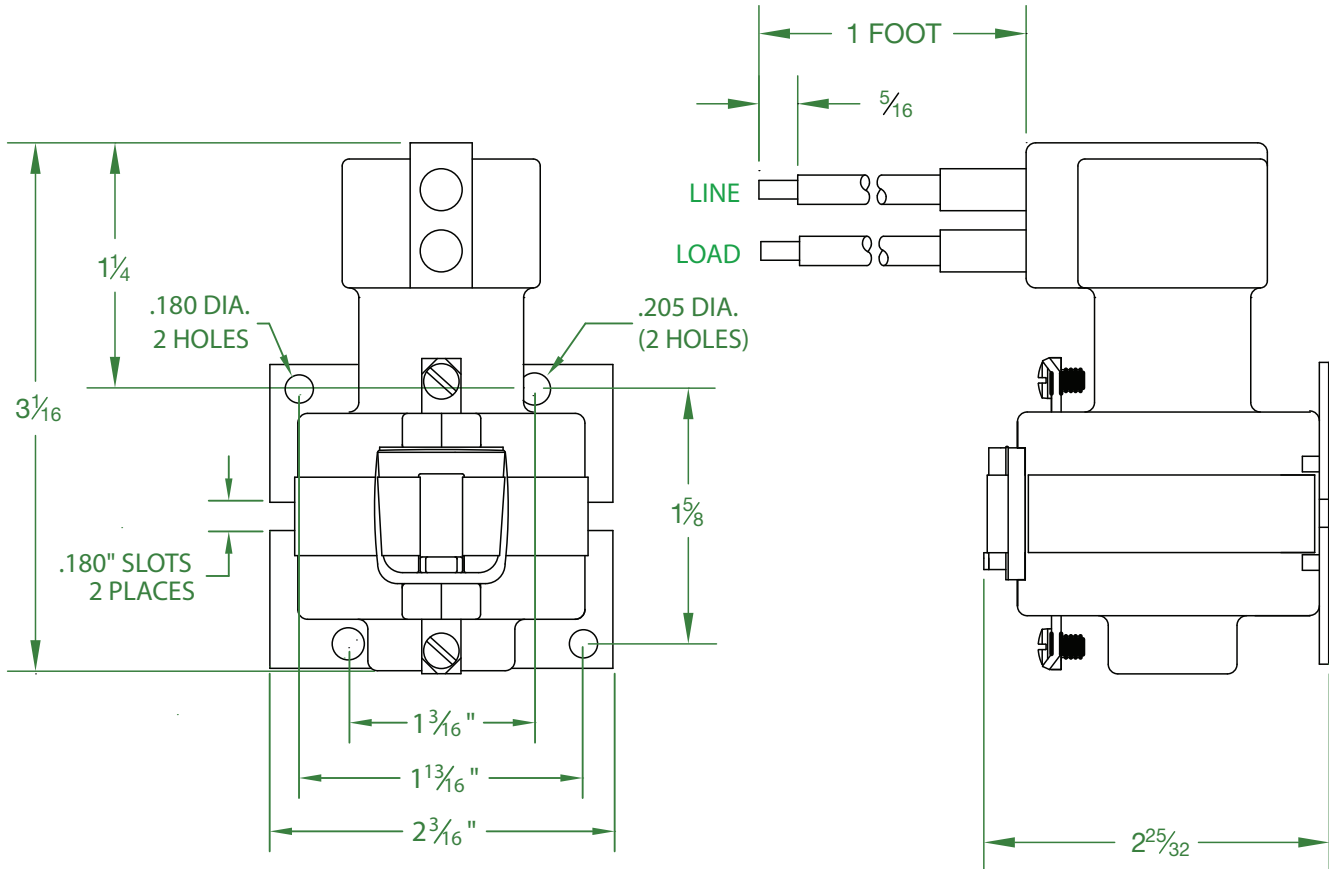

INDUSTRIAL CONTROL EQUIPMENT

SP-1027-120A



- * CONTACT RESISTANCE .003 ohms
- * DIELECTRIC WITHSTAND 2,500 VAC RMS
- * OPERATE TIME 50 MILLISECONDS
- * RELEASE TIME 80 MILLISECONDS
- * RATINGS:
 CONTACTS: 35 AMP @ 480 VAC
 RESISTIVE OR GENERAL PURPOSE
 COIL: 120V 50/60 Hz
 CURRENT: 53 mA
 RESISTANCE: 1,250 Ω
 VA: 6.4 WATTAGE: 3.5

- * TEMPERATURE RANGE -35° TO +85° C
- * TORQUE TO 7 IN-LB
- * COIL TERMINALS #6 BINDING HEAD SCREWS
- * 10 AWG WIRE
- * SINGLE POLE / SINGLE THROW
- * MAGNETICALLY ACTIVATED
- * MERCURY CONTACTOR

* LIFE CYCLE ENDURANCE TESTS: U.L. 508 @ 100,00 & CSA 22.2 @ 250,000 CYCLES