



Installation Manual
Submersible Solids
Handling Pumps

CP3NC

2 – 5 HP

@ 1750 RPM

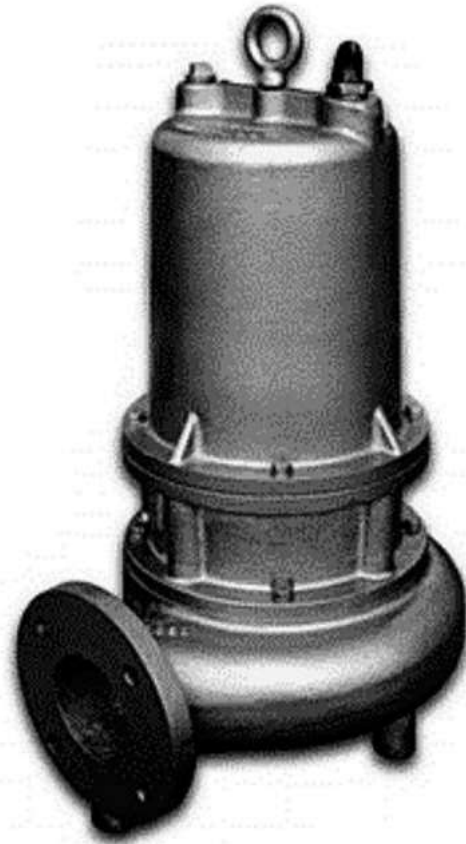

IMPORTANT! - Read all instructions in this manual before operating or servicing a pump.

General Safety Information

Before installation, read the following instructions carefully. Failure to follow instruction and Safety information could cause serious bodily injury, death and/or property damage. Each Champion pump is individually factory tested to insure proper performance. Closely following these instructions will eliminate potential operating problems, assuring years of trouble-free service.

▲ DANGER "Danger" indicates an imminent hazardous situation which, if not avoided, WILL result in death or serious injury.

▲ WARNING "Warning" indicates an imminent hazardous situation which, if not avoided, MAY result in death or serious injury.

▲ CAUTION "Caution" indicates a potentially hazardous situation which, if not avoided, MAY result in minor or moderate injury.

IMPORTANT - Champion Pump Company is not responsible for losses, injury or death resulting from failure to observe these safety precautions, misuse, abuse or misapplication of pumps or equipment.

 **ALL RETURNED PRODUCTS MUST BE CLEANED, SANITIZED, OR RECONTAMINATED PRIOR TO SHIPMENT, TO INSURE EMPLOYEES WILL NOT BE EXPOSED TO HEALTH HAZARDS IN HANDLING SAID MATERIAL. ALL APPLICABLE LAWS AND REGULATIONS SHALL APPLY.**

▲ WARNING Installation, wiring, and junction connections must be in accordance with the National Electric Code and all applicable state and local codes. Requirements may vary depending on usage and location.

Other brand and product names are trademarks or registered trademarks of their respective holders. Alteration Rights Reserved. 1/2011

▲ WARNING Installation and servicing is to be conducted by qualified personnel only.

▲ DANGER Keep clear of suction and discharge openings. Do not insert fingers in pump with power connected.

▲ WARNING Always wear eye protection when working on pumps. Do not wear loose clothing that may become entangled in moving parts

▲ DANGER Pumps build up heat and pressure during operation. Allow time for pumps to cool before handling or servicing.

▲ DANGER This pump is not intended for use in swimming pools or water installations where human contact with pumped fluid.

▲ DANGER Risk of electric shock. To reduce risk of electric shock, always disconnect pump from power source before handling. **Lock out power & tag.**

▲ WARNING Do not use these pumps in water over 104°F. High temperature units PFSE51HT 200°F. Do not exceed manufactures recommended maximum performance, as this could cause the motor to overheat.

▲ DANGER Do not lift, carry or hang pump by the electrical cables. Damage to the electrical cables can cause shock, burnes or death. **Never** handle connected power cords with wet hands. Use appropriate lifting device.

▲ WARNING Ground Fault Circuit Interrupter (GFCI) to be used with plug-in type power cord.

▲ WARNING Sump and sewage pumps often handle materials which could cause illness or disease. wear adequate protective clothing when working on a used pump or piping. Never enter a basin after it has been used.

▲ DANGER Failure to permanently ground the pump, motor and controls before connecting to power can cause shock, burns or death.

▲ WARNING These pumps are NOT to be installed in locations classified as hazardous in accordance with the National Electric Code, ANSI/NFPA 70.

▲ WARNING The Uniform Plumbing Code (UPC) states that sewage systems shall have an audio and visual alarm that signals a malfunction of the systems that is required to reduce the potential for property damage.

IMPORTANT! Prior to installation, record Model Number, MFG Date, Amps, Voltage, Phase and HP, from pump name plate for future reference. Also record the Voltage and Current Readings at Startup:

1 Phase Models	
Amps:	Volts:
3 Phase Models	
Amps L1-2:	Volts L1-2:
Amps L2-3:	Volts L2-3:
Amps L3-1:	Volts L3-1:

Model Number: _____

MFG Date: _____

PHASE: _____ HP: _____

Receiving Inspection

Upon receiving the pump, it should be inspected for damage or shortages. If damage has occurred, file a claim immediately with the company that delivered the pump. If the manual is removed from the packaging, do not lose or misplace.

Storage

Any product that is stored for a period longer than six (6) months from the date of purchase should be bench tested prior to installation. A bench test consists of, checking the impeller to assure it is free turning and a run test to assure the motor (and switch if provided) operate properly. Do not pump out of liquid.

Controls

Manual models require a separate approved pump control device or panel for automatic operation. Be sure the electrical specification of the control selected properly match the electrical specifications of the pump.

Submergence

The pump should always be operated in the submerged condition. The minimum sump liquid level should never be less than above the pump's volute (See Figure 1).

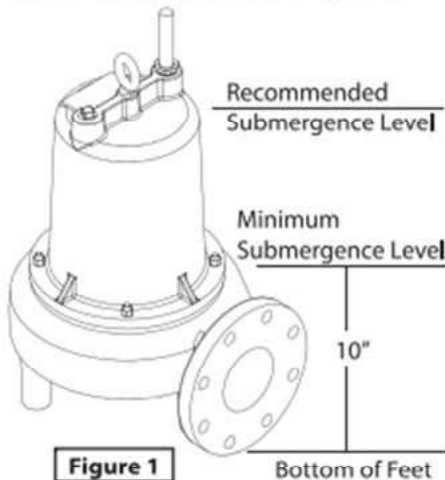

Figure 1

Installation

These pumps are recommended for use in a sump, basin or lift station. The sump, basin or lift station shall be sealed and vented in accordance with local plumbing codes. **This pump is designed to pump sewage, effluent or wastewater, nonexplosive and noncorrosive liquids and shall NOT be installed in locations classified as hazardous in accordance with the National Electrical Code (NEC) ANSI/NFPA 70 or Canadian Electric Code (CEC).** The pump should never be installed in a trench, ditch, or hole with a dirt bottom. The legs will sink into the dirt and the suction will become plugged.

The installation should be at a sufficient depth to ensure that all plumbing is below the frost line. If this is not feasible, remove the check valve and size the basin to accommodate the additional backflow volume.

Pumps are most commonly installed in simplex or duplex stations or basins with a slide rail system, which allows the pump(s) to be installed or removed without requiring personnel to enter the station, or resting on the basin floor.

Discharge Piping

Discharge piping should be as short as possible and sized no smaller than the pump discharge. **Do not reduce the discharge pipe size below that which is provided on the pump.** Both a check valve and a shut-off valve are recommended for each pump. The check valve is used to prevent backflow into the sump. The shut-off valve is used to manually stop system flow during pump servicing.

Liquid Level Controls

The level control(s) should be mounted on the discharge piping, a cable rack or float pole. The level control should have adequate clearance so it cannot hang up in it's swing and that the pump is completely submerged when the level control is in the "Off" mode. By adjusting the cord tether the control level can be changed. One cycle of operation should be observed, so that any potential problems can be corrected.

It is recommended that the level control float should be set to insure that the liquid in the sump never drops below the top of the motor housing or a minimum level of 10 inches above the basin floor.

Electrical Connections

Power cable:

The power cable mounted to the pump must not be modified in any way except for shortening to a specific application. Any splice between the pump and the control panel must be made in accordance with the electric codes. It is recommended that a junction box, if used, be mounted outside the sump or be of at a minimum Nema 4 construction if located within the wet well. **DO NOT USE THE POWER CABLE TO LIFT PUMP.**

Always rely upon a Certified Electrician for installation.

Overload Protection:

Single Phase - The stator in-winding overload protector used is referred to as an inherent overheating protector and operates on the combined effect of temperature and current. This means that the overload protector will trip out and shut the pump off if the windings become too hot, or the load current passing through them becomes too high.

SUBMERSIBLE SOLIDS HANDLING PUMP

Series: CP3NC
2 - 5 HP / 1750 RPM
Discharge: 3"
Spherical solids handling: 2½"



DISCHARGE

3", 125lb, flange horizontal.

LIQUID TEMPERATURE

104 °F (40 °C) continuous, 140 °F (60 °C) intermittent operation.

VOLUTE

Cast iron ASTM A-48 class 30.

MOTOR HOUSING

Cast iron ASTM A-48 class 30.

SEAL PLATE

Cast iron ASTM A-48 class 30.

IMPELLER

Design: 2 vane, semi-open, with vanes on back side.

Material: cast iron ASTM A-48 class 30.

SHAFT

416 series stainless steel.

SQUARE RINGS

Buna-N.

PAINT

Air dry enamel, water based.

SEAL

Design: dual, mechanical, oil filled chamber.

Material: silicon carbide with Viton type 01 outer seal, carbon ceramic with Buna-N type 01 inner seal, with stainless steel hardware.

HARDWARE

300 series stainless steel.

CORDENTRY

40 ft of cord, epoxy sealed housing with secondary pressure grommet for sealing and strain relief.

MOTOR

NEMA B, three phase, 230 & 460 volts, 60 Hz, 1750 RPM, oil filled, with class F insulation. Requires overload protection to be included in control panel.

OPTIONAL EQUIPMENT

Additional cord, tungsten carbide seal, slide rail coupling

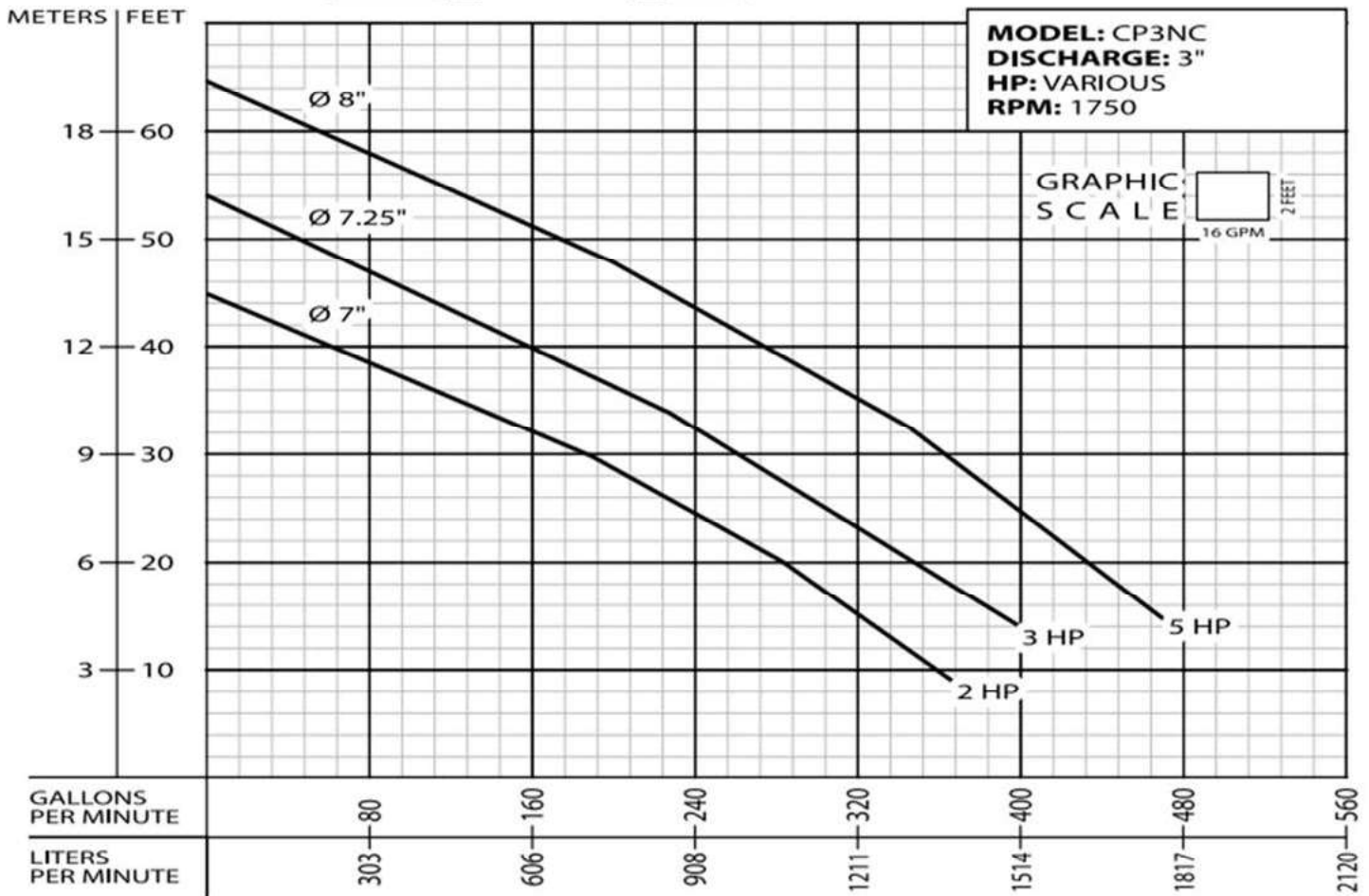
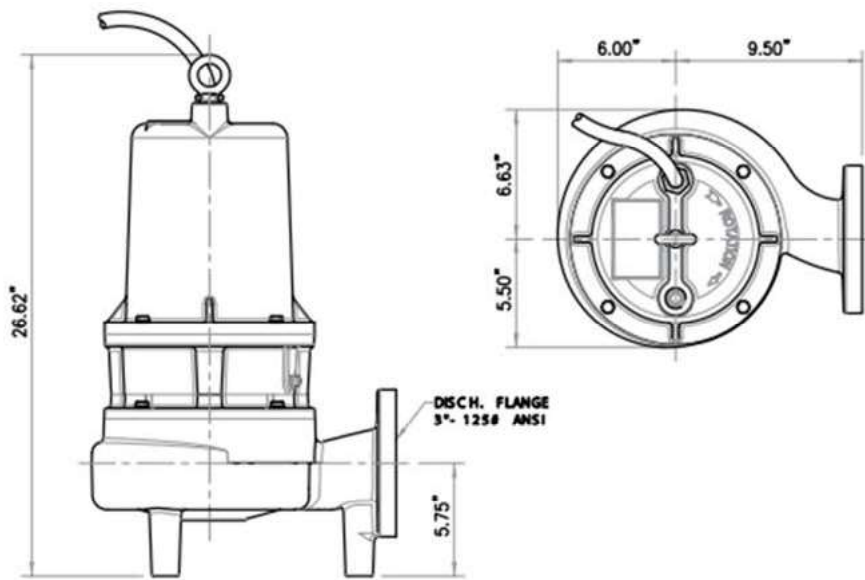

MODEL	HP	VOLTS	PHASE	RPM	MAX AMPS	LOCKED ROTOR AMPS	NEMA CODE	CORD SIZE	CORD TYPE	CORD LENGTH	WEIGHT
CP3NC203DS	2	230	3	1750	14.3	40	F	14/4	STOW	40'	194
CP3NC204DS	2	460	3	1750	7.2	20	F	14/4	STOW	40'	194
CP3NC303DS	3	230	3	1750	15.9	49.5	H	14/4	STOW	40'	200
CP3NC304DS	3	460	3	1750	8	24.8	H	14/4	STOW	40'	200
CP3NC503DS	5	230	3	1750	22.1	63.6	E	10/4	STOW	40'	205
CP3NC504DS	5	460	3	1750	11	31.8	E	14/4	STOW	40'	205

IMPORTANT!

1. Never use this pump to handle explosive liquids. 2. This pump is not approved to be used in swimming pools, recreational installations or any application where human contact may be common. 3. Pump may be operated "dry" for extended periods without damage to motor &/or seals. 4. Testing is performed with water specific gravity of 1.0 @ 68 °F (20 °C); other fluids may vary performance.



Risk of electric shock. Always disconnect the pump from the power source before handling inspections or repairs.

Symptom	Possible Cause(s)	Corrective Action
Pump will not run	<ol style="list-style-type: none"> 1. Poor electrical connection, blown fuse, tripped breaker or other interruption of power; improper power supply 2. Motor or switch inoperative (go to manual operation) <ol style="list-style-type: none"> 2a. Float movement restricted 2b. Switch will not activate pump or is defective 2c. Defective motor 3. Insufficient liquid level 	<ol style="list-style-type: none"> 1. Check all electrical connections for security. Have electrician measure current in motor leads, if current is within $\pm 20\%$ of locked rotor Amps, impeller is probably locked. If current is 0, overload may be tripped. Remove power, allow pump to cool, then re-check current. 2a. Reposition pump or clean basin as required to provide adequate clearance for float 2b. Disconnect level control. Set ohmmeter for a low range, such as 100 ohms full scale and connect to level control leads. Actuate level control manually and check to see that ohmmeter shows zero ohms for closed switch and full scale for open switch. (Float Switch) 2c. Check winding insulation (Megger Test) and winding resistance. If check is outside of range, dry and re-check. If still defective, replace per service instructions. 3. Make sure liquid level is above the pump 4. Re-check all sizing calculations to determine proper pump size. 5. Check discharge line for restrictions, including ice if line passes through or into cold areas. 6. Remove and examine check valve for proper installation and freedom of operation 7. Open valve 8. Check impeller for freedom of operation, security and condition. Clean impeller cavity and inlet of any obstruction 9. Loosen union slightly to allow trapped air to escape. Verify that turn-off level of switch is set so that the suction is always flooded. Clean vent hole 10. Check rotation. If power supply is three phase, reverse any two of three power supply leads to ensure proper impeller rotation 11. Repair fixtures as required to eliminate leakage 12. Check pump temperature limits and fluid temperature 13. Replace portion of discharge pipe with flexible connector or tighten existing piping. 14. Turn to automatic position 15. Check for leaks around basin inlet and outlets
Pump will not turn off	<ol style="list-style-type: none"> 2a. Float movement restricted 2b. Switch will not activate pump or is defective 4. Excessive inflow or pump not properly sized for application 9. Pump may be air locked causing pump not to flow 14. H-O-A switch on panel is in "HAND" position 	
Pump hums but doesn't run	<ol style="list-style-type: none"> 1. Incorrect low voltage 8. Impeller jammed or loose on shaft, or inlet plugged 	
Pump delivers insufficient capacity	<ol style="list-style-type: none"> 1. Incorrect low voltage 4. Excessive inflow or pump not properly sized for application 5. Discharge restricted 6. Check valve partially closed or installed backwards 7. Shut-off valve closed 8. Impeller jammed or loose on shaft, or inlet plugged 9. Pump may be air locked causing pump not to flow 10. Piping fixtures leaking or discharge before the nozzle 	
Pump cycles too frequently or runs periodically when fixtures are not in use	<ol style="list-style-type: none"> 6. Check valve partially closed or installed backwards 11. Fixtures are leaking 15. Ground water entering basin 	
Pump shuts off and turns on independent of switch, (trips thermal overload protector). CAUTION! Pump may start unexpectedly. Disconnect power supply.	<ol style="list-style-type: none"> 1. Incorrect low voltage 4. Excessive inflow or pump not properly sized for application 8. Impeller jammed or loose on shaft, or inlet plugged 12. Excessive water temperature (internal protection only) 	
Pump operates noisily or vibrates excessively	<ol style="list-style-type: none"> 2c. Worn bearings, motor shaft bent 5. Debris in impeller cavity or broken impeller 10. Pump running backwards 13. Piping attachments to building structure too loose or rigid 	

NOTE: Champion Pumps assumes no responsibility for damage or injury due to disassembly in the field. Disassembly of the pumps or supplied accessories other than at Champion Pumps or its authorized service centers, automatically voids warranty.

Repair Parts

For Repair Part Please supply: Model Number and MFG Date as shown on Name Plate, and Part Description and Part Number as shown on Parts List.

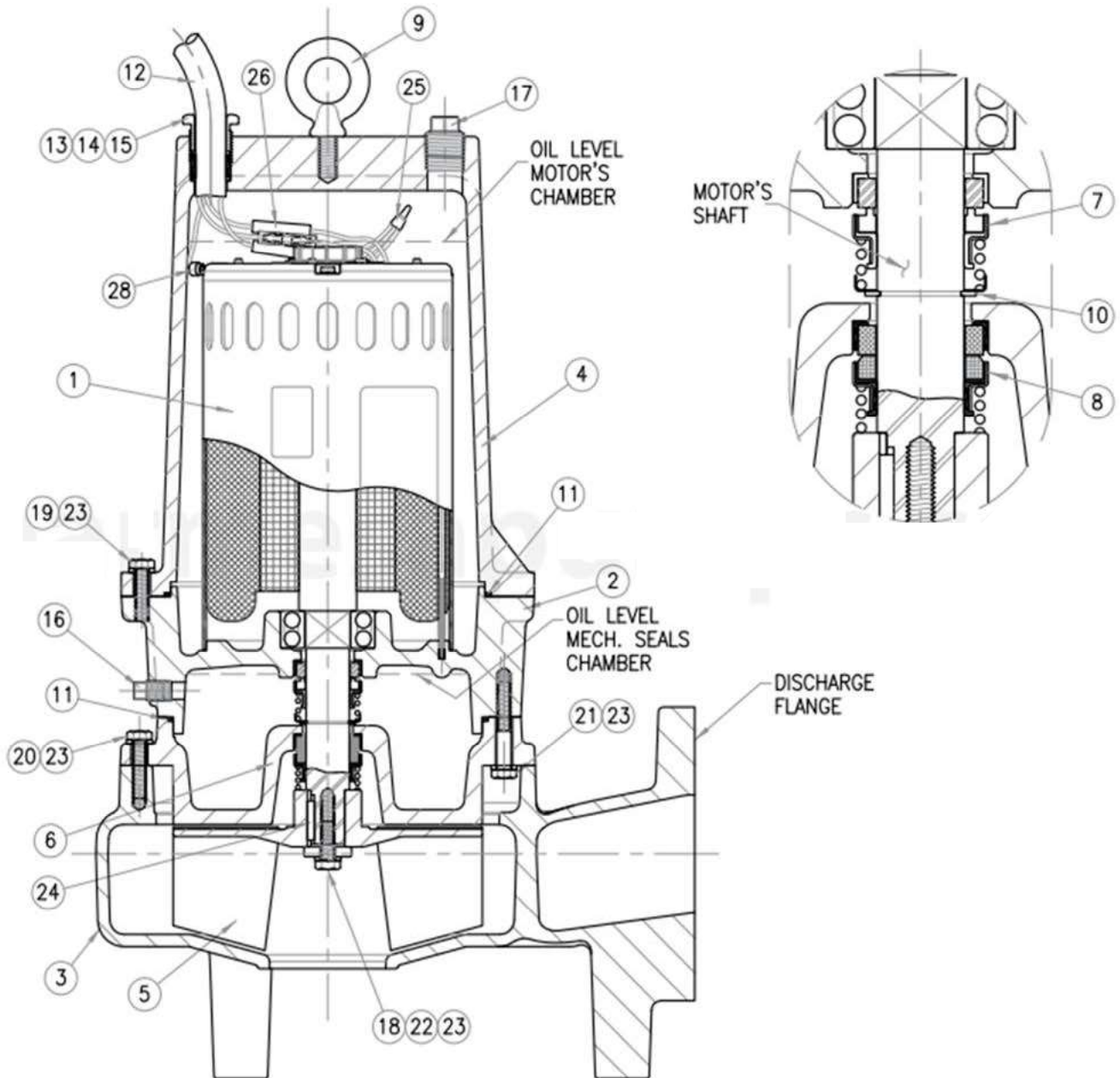

For repair part please supply: Model Number and Serial as shown on Name Plate, and Part Description and Part Number as shown on Parts List.

Champion Pump Company, Inc • P.O. Box 528 • Ashland, OH 44805
Phone 419-281-4500 • toll free 800-659-4491 • fax 419-616-1100

Repair Parts

For Repair Part Please supply: Model Number and MFG Date as shown on Name Plate, and Part Description and Part Number as shown on Parts List.

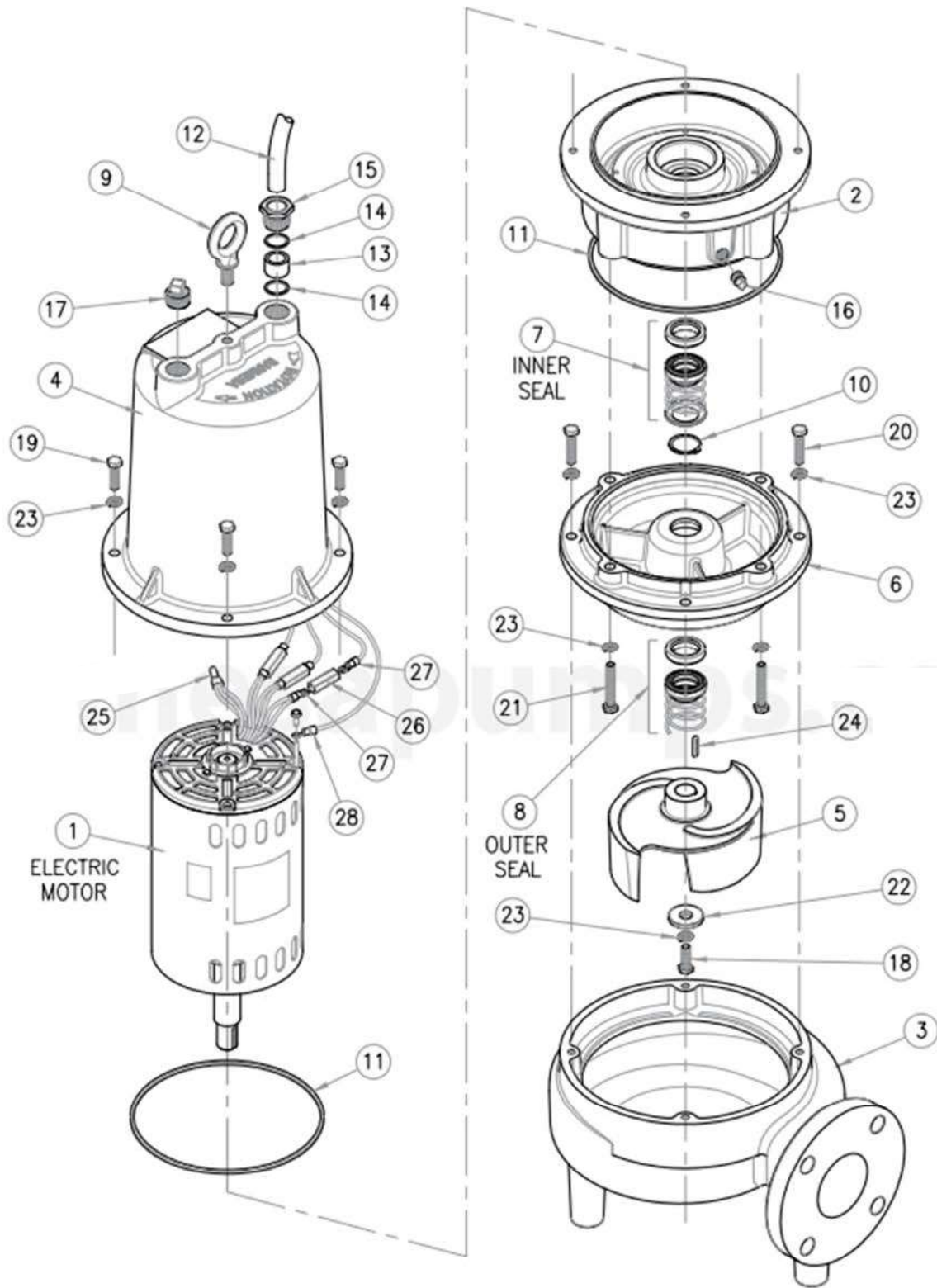

For Repair Part Please supply: Model Number and MFG Date as shown on Name Plate, and Part Description and Part Number as shown on Parts List.

ITEM	PART #	DESCRIPTION	QTY.
1		Electric motor	1
	40040068	7.5 HP, 3 ph, 230/460 V, frame 56Z	
	40040066	3 HP, 3 ph, 230/460 V, frame 56Z	
2	03040027	Bearing housing	1
3	03090096	Body	1
4	03100002	Motor housing	1
5		Impeller	1
	03140094	Diameter 8.000", for 7.5 HP	
	03140094B	Diameter 7.250", for 5 HP	
	03140094C	Diameter 7.000", for 3 HP	
	03140094D	Diameter 6.500", for 2 HP	
6	03180030	Seal plate	1
7	31030211	Mechanical seal Ø1 $\frac{1}{8}$ " (Carbon/Ceramic/Buna/SS)	1
8	31030137	Mechanical seal Ø1 $\frac{1}{8}$ " (Silicon/Silicon/Viton/SS)	1
9	91010406	Handle	1
10	31010017	Retaining ring # 5100-112	1
11	92010083	Gasket # 33730	2
12	31030003	Power cable 4 x10" (12.40 meters)	1
13	92010001	Grommet # 514	1
14	91010055	Washer # 54746	2
15	30400903	Hex head plug SE103-203-4SE	1
16	93010143	Pipe plug 1/4"	1
17	93010148	Pipe plug 3/4"	1
18	91010345C	Screw 3/8" x 1 $\frac{1}{4}$ " SS	1
19	91010345C	Screw 3/8" x 1 $\frac{1}{4}$ " SS	4
20	91010346	Screw 3/8" x 1 $\frac{1}{2}$ " SS	4
21	91010347C	Screw 3/8" x 2 $\frac{1}{4}$ " SS	4
22	30400426B	Impeller washer	1
23	91010061	Spring washer 3/8" SS	13
24	30400631	Keyway 3/16" x 1 $\frac{1}{8}$ "	1
25		Wire connector #1921	
	94010012	For 230 volts	1
		For 460 volts	3
26	94010027	Connector	3
27	94010041	Female terminal	6
28	94010043	Terminal	1
	31010031	DTE. Oil light	12 L
	99210007	Data plate	1
	99230102	Rivet SS # 001628	4

Manufacturer warrants, to the immediate purchaser and subsequent initial owner during the warranty period, every new pump to be free from defects in material and workmanship under normal use and service, when properly used and maintained, for a period of eighteen (18) months from date of manufacture or twelve (12) months from date of installation (whichever ever comes first). Failure due to wear due to excessive abrasives is not covered. The initial owner is the purchaser who first uses the pump after its initial installation, or for non-permanent installation, the first owner who uses the pump. The date of installation shall be determined by a dated sales receipt noting the model and serial number of the pump. The dated sales receipt must accompany the returned pump. Product will be repaired, replaced or remanufactured at Manufacturer's option. No allowance will be made for shipping charges, damages, labor or other charges that may occur due to product failure, repair or replacement. This warranty does not apply to and there shall be no warranty for any material or product that has been disassembled without prior approval of Manufacturer, subjected to misuse, misapplication, neglect, alteration, accident or act of God; that has not been installed, operated or maintained in accordance with Manufacturer's installation instructions; that has been exposed to outside substances including but not limited to the following: sand, gravel, cement, mud, tar, hydrocarbons, hydrocarbon derivatives (oil, gasoline, solvents, etc.), or other abrasive or corrosive substances, wash towels or feminine sanitary products, etc. in all pumping applications. The warranty set out in the paragraph above is in lieu of all other warranties expressed or implied; and we do not authorize any representative or other person to assume for us any other liability in connection with our products. Contact Manufacturer to obtain any needed repair or replacement of part(s) or additional information pertaining to our warranty.

MANUFACTURER EXPRESSLY DISCLAIMS LIABILITY FOR SPECIAL, CONSEQUENTIAL OR INCIDENTAL DAMAGES OR BREACH OF EXPRESSED OR IMPLIED WARRANTY; AND ANY IMPLIED WARRANTY OF FITNESS FOR A PARTICULAR PURPOSE AND OF MERCHANTABILITY SHALL BE LIMITED TO THE DURATION OF THE EXPRESSED WARRANTY.

Some states do not allow limitations on the duration of an implied warranty, so the above limitation may not apply to you. Some states do not allow the exclusion or limitation of incidental or consequential damages, so the above limitation or exclusion may not apply to you. This warranty gives you specific legal rights and you may also have other rights which vary from state to state.

Start-Up Report / Warranty Registration

Please fill out the following questions as completely and accurate as possible. Please mail to Champion Pump Company, Inc. – P. O. Box 528 – Ashland, OH 44805.

REPORTS THAT ARE NOT RETURNED CAN DELAY OR VOID WARRANTY.

Pump Owner's

Name: _____

Address: _____

Location of installation: _____

Phone: _____

Purchased from: _____

Pump Model _____ Serial # _____ Date Code: _____

NOTE: PUMPS REQUIRING CAPACITORS IN THE PANELS MUST HAVE PROPER CAPACITOR KIT OR WARRANTY IS VOID.

Date Installed: _____

Does impeller turn freely by hand? YES _____ NO _____

Condition of cord jacket? Good _____ Fair _____ Poor _____

Was equipment stored? _____ How long? _____

Liquid being pumped _____

Debris in bottom of station? _____ Was debris removed in your presence? _____

Discharge pipe size? _____ Length of pipe? _____ Static lift? _____

Does station appear to operate at the proper rate? _____ Pump down time? _____

Voltage At Wiring Terminal L1-L2 _____ L2-L3 _____ L1-L3 _____

Run Amps L1 _____ L2 _____ L3 _____

3 Phase Models – Check Proper Rotation? Yes / NO

Difficulties during start up: _____

I certify this report to be accurate (start up person) _____

Employed by _____ Date: _____