

# MDI

## 2 HP Dual Seal Grinder Pump Internal Start Components



The MDI grinder pumps easily handle residential, light commercial or industrial sanitary waste, reducing it to fine slurry. The **G2-21SI** (**G2-21HI**) pump is designed for use in pressure sewer applications or any piping network.

The recessed vortex impeller design of the **G2-21SI** (**G2-21HI**) grinder pump provides trouble free, non-overloading operation over the entire performance curve. The **G2-21SI** pump produces capacities to 43 gpm with heads to 106 feet (**G2-21HI** produces 20 gpm to 130 gpm).

The modular design provides quick access to the internal start capacitor kit. Hardened stainless steel grinder assembly and many quality features.

Some of the other **G2-21SI** (**G2-21HI**) series pump features:

- \* Strong, 2 HP, 200/230 volt motor
- \* Internal start component (no control box req'd)
- \* Potted cord cap assembly
- \* Dual silicon carbide shaft seals
- \* 3 Bearings
- \* Pressed in motor

### Performance Curve

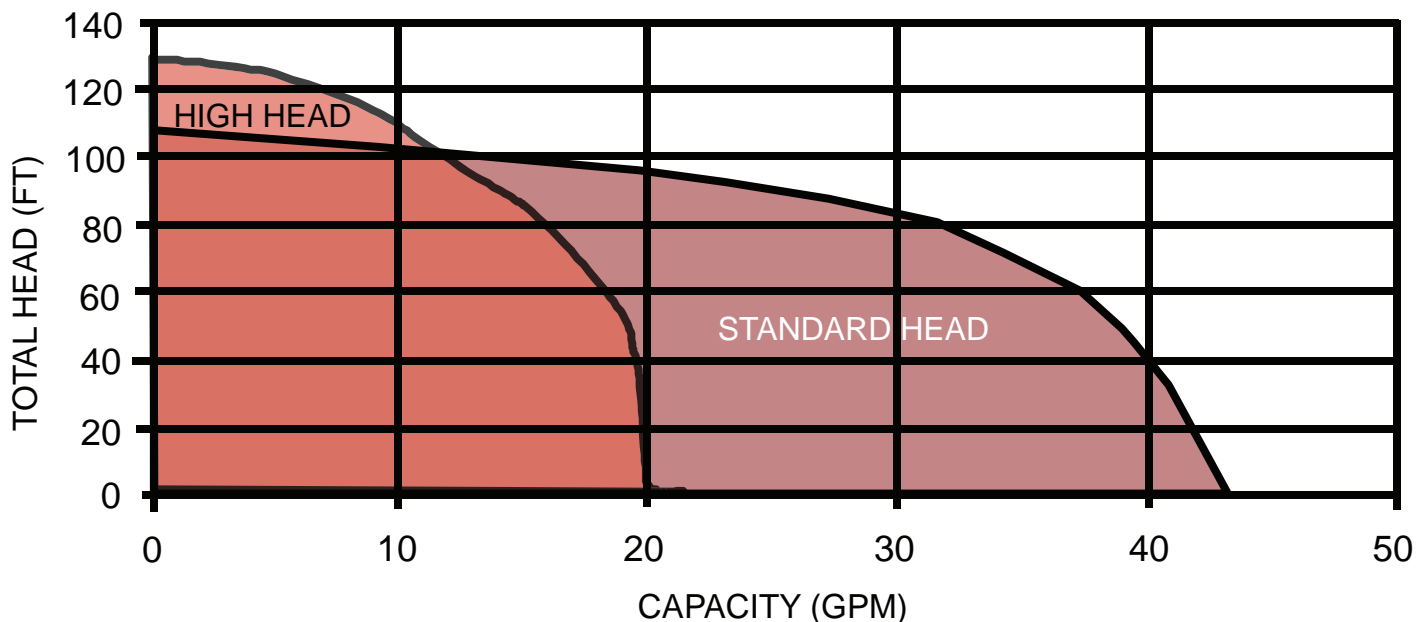

# G2-21SI/G2-21HI - Features and Benefits

## 1. Triple Sealed Cable Entrance

Stainless steel strain relief cord grip with compression grommet protects outer cord jacket. Epoxy filled inner cord cap with individually soldered wires provide anti-wicking moisture protection to the motor even if power cable is cut or damaged.

## 2. Internal Start Kit

Start / Run capacitor with relay securely positioned in dry compartment. Rubber compression grommet for wire leads to motor prevents oil from entering chamber. 4 bolts quickly removes cord cap for easy servicing.

## 3. Modular Pump Design

Commonality of parts across the pump product line minimizes the amount of parts required for servicing. Heavy duty ASTM A48, Class 30 cast iron components.

## 4. Strong Motor

High torque for powerful (200/230v) and reliable pump operation. Pressed stator securely holds motor and efficiently transfers heat. Class F insulation with overload protection in oil filled chamber for cool operation and long motor life.

## 5. 3-Bearing Support

Motor / Pump shaft securely held with upper and lower ball bearing plus addition sleeve bearing in lower seal chamber. Long 50,000 hour B-10 bearing life.

## 6. Double Mechanical Seal Protection

Dual silicon carbide mechanical shaft seals provide twice the moisture protection for the motor. Dual seals are housed in a secondary oil filled seal chamber. Tougher silicon carbide seals better handles sand, grit and abrasive materials.

## 7. Non-Overloading Hydraulic Design

The recessed centrifugal impeller allows 100% performance curve operation from shut-off to maximum flow without damage to the pump or system. The recessed vortex impeller is out of the passageway of fluid flow, eliminating concerns of blockage or wear.

## 8. Proven Grinder Assembly

Hardened (Rockwell 56-60) stainless steel grinder assembly has 30+ years proven field experience. The reversible grinder ring and grinder impeller effectively reduces solids into a fine slurry, easily passable in a piping system without concerns of clogging. Highly efficient 16,600 (G2-21HI 7,400) cuts per second.

## 9. Easy Piping Connection

Removable 1-1/4" NPT connection flange for simple and easy connection to discharge piping.

## 10. Accessories Included

Stainless steel lifting handle and anti-vibration rubber mounting feet are included with the pump.

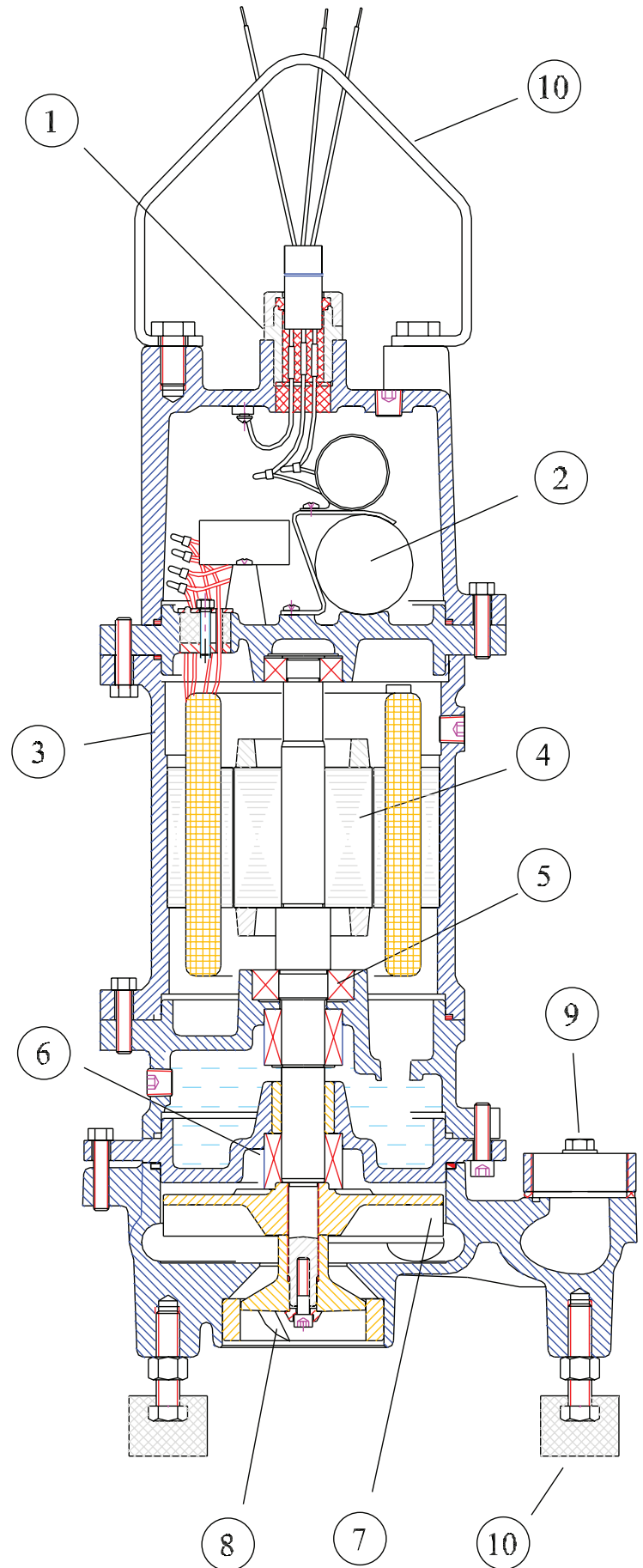

Assembled  
in U.S.A!

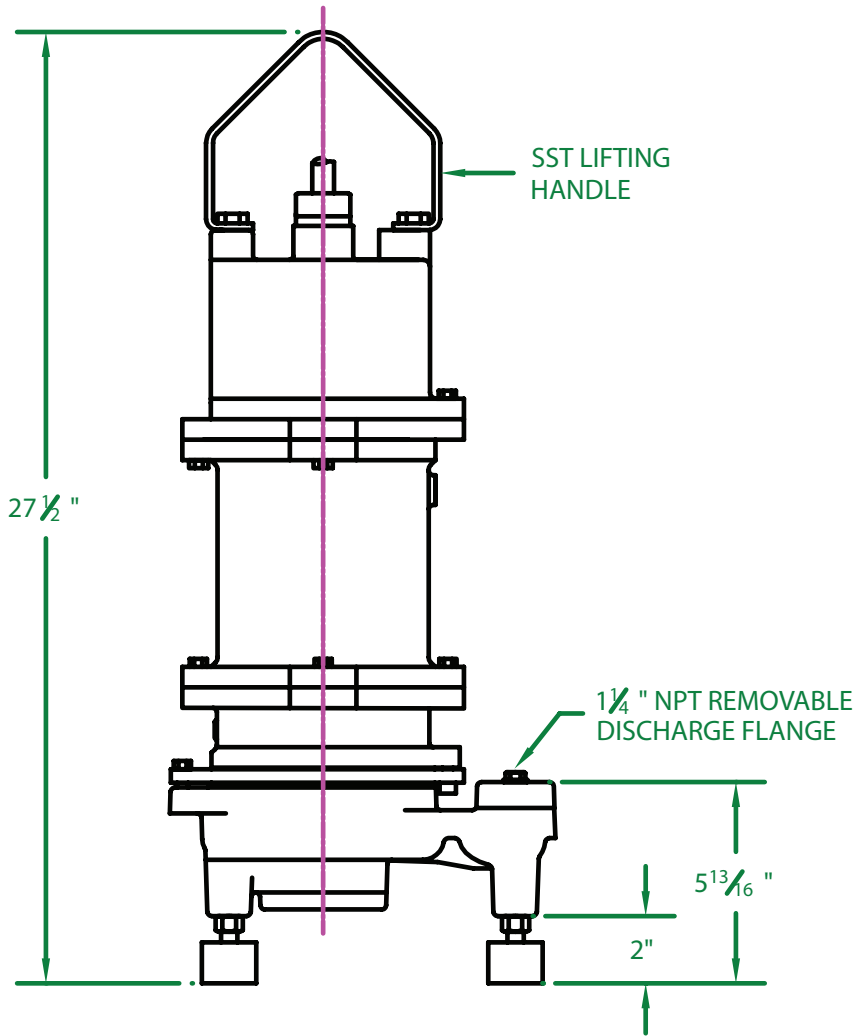
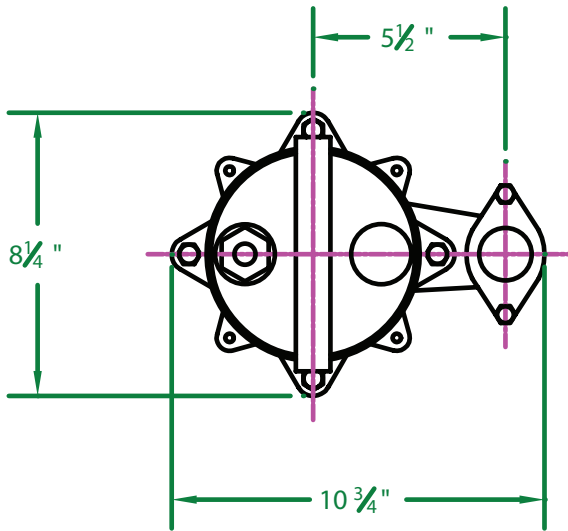

200/208 VAC 1-Phase

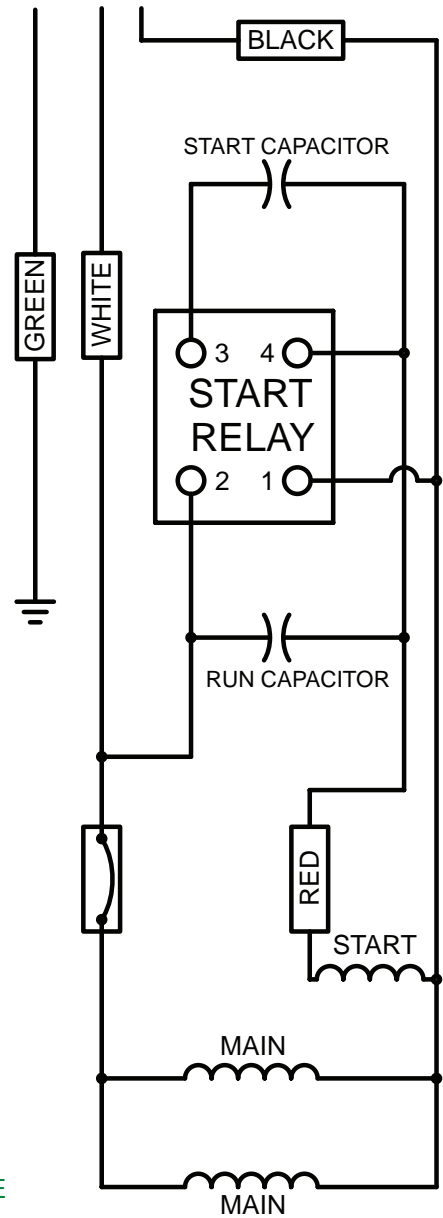

OHMS  
WHITE TO BLACK 1.2

**MDI** Mercury Displacement Industries, Inc.  
 Phone (269) 663-8574 Fax (269) 663-2924  
 P.O. Box 710 25028 US 12 East Edwardsburg, MI 49112-0710

Title: 2HP 200/208 VAC Internal Start Grinder Pump

Scale: NONE

Iss. By: J.J.S.

Rev. B 03-08-2012

Date: 02-24-2010