

Switching Power Supply Type SPD 10W DIN rail mounting



- Universal AC input full range
- Installation on DIN rail 7.5 or 15mm
- Short circuit protection
- Overload protection
- High efficiency
- LED indicator for DC power ON
- LED indication for DC low
- Internal input filter
- CE, TUV approved and cULus Listed

Product Description

The Switching power supplies SPD series are specially designed to be used in all automation application where the

installation is on a DIN rail and compact dimensions and performance are a must.

Ordering Key

SP D 24 10 1 B

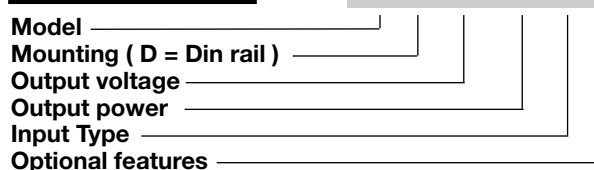

Input type: 1= single phase

Approvals



Optional Features

Description	code
Spring connectors	B

Output performances

Model	Output Voltage (VDC)	Output Current (A)	Voltage Trim Range		DC on LED (VDC Min.)	DC low LED (VDC Min.)	Typical Efficiency
			Min. (VDC)	Max. (VDC)			
SPD05	5	2	4.5	5.75	4.5	3.75	73%
SPD12	12	0.84	10.8	13.8	10.8	9	75%
SPD15	15	0.67	13.5	17.25	13.5	11.25	76%
SPD24	24	0.42	21.6	28.8	21.6	18	76%

Output data

Line regulation	± 1%	Output Voltage accuracy	± 1%
Load regulation	± 2%	Temperature coefficient	± 0.02%/°C
Minimum load	0%	Hold up Time Vi = 115Vac	25ms
Transient recovery time	300µs	Hold up time Vi = 230Vac	100ms
Ripple and noise	50mVpp		

Input data

Rated input voltage	100 - 240	Frequency range	47- 63 Hz
Voltage range		Inrush current	
AC	90 - 265 Vac	Vi= 115Vac	10A
DC	120 - 370 Vdc	Vi= 230Vac	18A

Controls and Protections

Overload	110 – 135%	Overvoltage Protection	125 – 145%
Input Fuse	T2A/250Vac internal*	Output Short Circuit	Hiccup mode

General data (@ nominal line, full load, 25°C)

Ambient temperature	-10°C to 71°C	Switching frequency	100kHz
Derating (>60°C to +71°C)	3%/°C	MTBF (MIL-HDBK-217F)	787.000h
Ambient humidity	20 - 95%RH	Case material	Plastic: PC, UL94-V0
Storage	-25°C to +85°C	Dimensions L x W x D	90 x 22.5 x 115
Protection degree	IP20	Weight	120g
Cooling	Free air convection		

Approvals and EMC

Insulation voltage I / O	3.000Vac	CE	EN50081-1 / EN55022 Class B EN50082-1 / EN55024 EN61000-3-2 EN61000-3-3
Insulation resistance	100Mohm		
UL / cUL	UL508, UL60950-1, UL1310 Class 2 Recognised		
TUV	EN60950-1		

* fuse not replaceable by user

Block diagrams

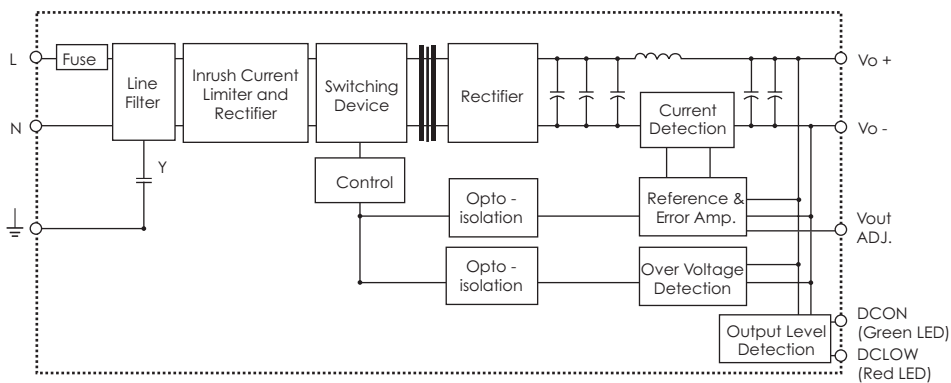

Pin assignement and front controls

Pin No.	Designation	Description
1	V+	Positive output terminal
2	V-	Negative output terminal
3	GND	Ground terminal to minimise High frequency emissions
4	N	Neutral input (no polarity with DC input)
5	L	Phase input (no polarity with DC input)
	Vout ADJ.	Trimmer for fine output voltage adjustment
	ON	DC output ready LED
	LO	DC low indicator LED

Derating Diagram

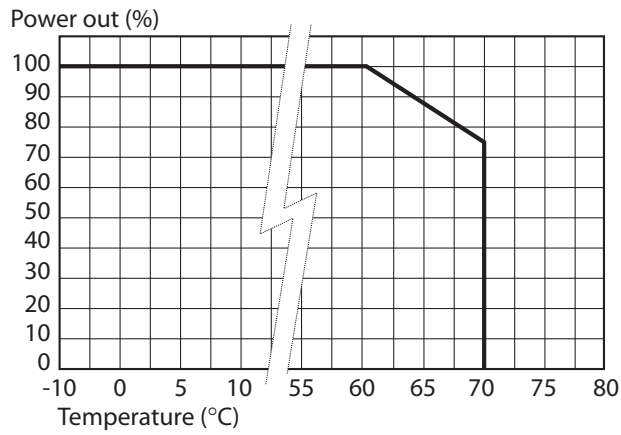

Mechanical Drawings

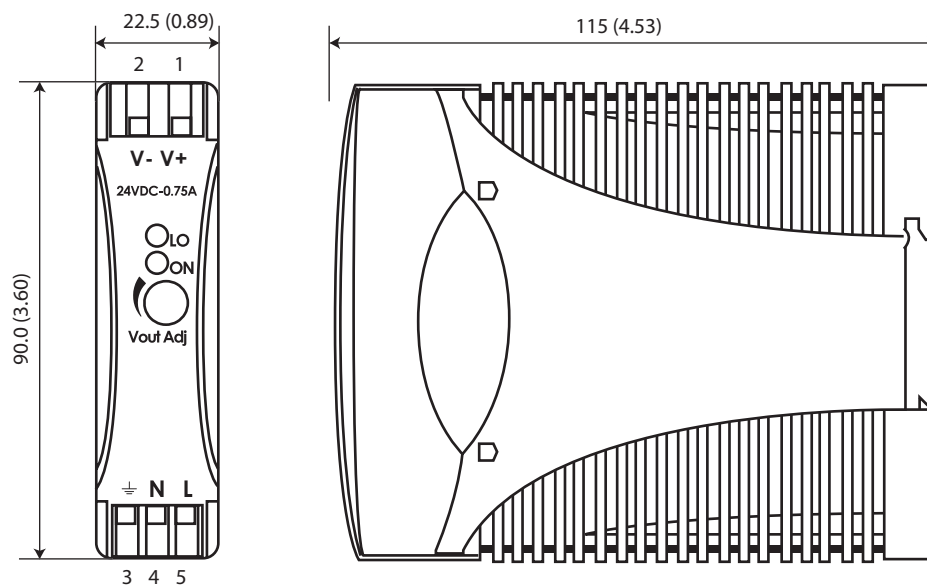

Installation

Ventilation and cooling

Normal convection
 All sides 25mm free space
 for cooling is recommended

Connector size range

Solid: 0.2 – 2mm²
 (AWG24-14)
 (use copper conductors only)